

**Part XIX :Details of Standards for  
Tailpipe Emissions from Petrol, CNG,  
LPG and Diesel Engined Vehicles and  
Test Procedures Effective for Mass  
Emission Standards (Bharat Stage IV) for  
L7 (Quadricycle ) category Vehicles**

Date of hosting on website: 29.05.2018

Last date for comments: 14.06.2018

<b>MoRTH/CMVR/TAP-115/116</b>	<b>STANDARDS FOR PETROL / DIESEL ENGINED VEHICLES</b>	
<b>ISSUE NO. 4</b>		<b>PART XIX</b>
<b>Part XIX :Details of Standards for Tailpipe Emissions from Petrol, CNG, LPG and Diesel Engined Vehicles and Test Procedures Effective for Mass Emission Standards (Bharat Stage IV) for L7 (Quadricycle ) category Vehicles</b>		

<b>Chapter</b>	<b>Details</b>
1.	Overall Requirements
2.	Essential Characteristics of the Vehicle and Engine and Information Concerning the Conduct of Tests
3.	Type I Test on SI Engines, CNG, LPG and Diesel Engine Vehicles (Verifying the Average Tailpipe Emissions of Gaseous and Particulate Pollutants)
4.	Resistance to Progress of a Vehicle - Measurement Method on the Road-Simulation on a Chassis Dynamometer
5.	Verification of Inertia other than Mechanical
6.	Gas Sampling Systems
7.	Calibration of Chassis Dynamometers, CVS System and Gas Analysis System and Total System Verification
8.	Calculation of the Mass Emissions of Pollutants and Fuel Consumption
9.	Type II Test on SI Engines (Verifying Carbon Monoxide, Hydrocarbons Emission at Idling)
10.	Type V Test: Description of the Ageing Test for Verifying the Durability of Anti Pollution Devices
11.	Type IV Test : Evaporative Emission Test
12.	Test Procedure for On-Board Diagnostics I (OBD - I)

**Chapter 1**  
**OVERALL REQUIREMENTS**

1	<b>Scope</b>
1.1	This Part applies to the tailpipe emission of L7 ( <b>Quadricycle</b> ) <b>category</b> vehicles equipped with spark ignition engines (Petrol, CNG, LPG) and compression ignition engines (Diesel) <b>for Bharat Stage IV with effect from</b> the date of Gazette Notification.
1.1.1	Refer Part XIV, Chapter 16 for tailpipe emission of Hybrid Electric Vehicles.
1.2	This Part should be read in conjunction with the applicable Gazette Notification under CMVR for which the vehicle is subjected to test.
2	<b>Definitions :</b>
2.1	<b>Quadricycles</b> : refer AIS 53 as amended from time to time or Gazette Notification.
2.2	<b>Spark Ignition Engine</b> : Means an internal combustion engine in which the combustion of the air/fuel mixture is initiated at given instants by a hot spot, usually an electric spark.
2.3	<b>Compression Ignition Engine</b> : Means an engine which works on the compression-ignition principle (e.g. diesel engine).
2.4	<b>Idle Speed</b> : Means the engine rate, in revolution per minute, with fuel system controls (accelerator and choke) in the rest position, transmission in neutral and clutch engaged in the case of vehicles with manual or semiautomatic transmission, or with selector in park or neutral position when an automatic transmission is installed, as recommended by the manufacturer.
2.5	<b>Normal Thermal Conditions</b> : Means the thermal conditions attained by an engine and its drive line after a run of at least 15 minutes on a variable course, under normal traffic conditions
2.6	<b>Gaseous Pollutants</b> : Means the exhaust gas emissions of carbon monoxide, oxides of nitrogen, expressed in nitrogen dioxide (NO <sub>2</sub> ) equivalent, and hydrocarbons assuming a ratio of: <ul style="list-style-type: none"> <li>- C<sub>1</sub>H<sub>1.85</sub> for petrol,</li> <li>- C<sub>1</sub>H<sub>1.86</sub> for diesel,</li> <li>- C<sub>1</sub>H<sub>2.525</sub> for LPG,</li> <li>- CH<sub>4</sub> for NG.</li> </ul>
2.7	<b>Particulate Pollutants</b> : Means components of exhaust gas which are removed from the diluted exhaust gas at a maximum temperature of 52°C (325 K) by means of filters described in Chapter 3 of this part.
2.8	<b>Tailpipe emissions means</b> <ul style="list-style-type: none"> <li>- For positive ignition engines, the emission of gaseous pollutants</li> <li>- For compression ignition engines, the emission of gaseous and particulate pollutants.</li> </ul>

2.9	<b>Unladen Mass</b> : Means the mass of the vehicle in running order, without crew, passengers or load, but with the fuel tank 90 % full and the usual set of tools and spare wheel on board where applicable.
2.10	<b>Reference Mass:</b> Means the "Unladen Mass" of the vehicle increased by a uniform figure of 150 kg for Quadricycle vehicle.
2.11	<b>Gross Vehicle Weight (GVW):</b> Means the technically permissible maximum weight declared by the vehicle manufacturer.
2.12	<b>Cold Start Device</b> : Means a device which enriches the air fuel mixture of the engine temporarily and, thus, to, assist engine start up like choke.
2.13	<b>Starting Aid</b> : Means a device which assists engine start up without enrichment of the fuel mixture, e.g. glow plug, change of injection timing for fuel-injected spark ignition engine, etc.
2.14	<b>Engine capacity means</b> : For reciprocating piston engines, the nominal engine swept volume.
2.15	<b>Anti pollution device</b> : means those components of the vehicles that control and / or limit tail pipe and evaporative emissions
2.16	<b>Type Approval of a vehicle:</b> Means the type approval of a vehicle model with regard to the limitation of tailpipe emissions from the vehicles.
2.17	<b>Vehicle Model</b> : Means a category of power-driven vehicles which do not differ in such essential respects as the equivalent inertia determined in relation to the reference weight of engine and vehicle characteristics which effects the vehicular emission and listed in Chapter 2 and Chapter 12 of this part.
2.18	<b>Vehicle for Type Approval Test:</b> Means the fully built vehicle incorporating all design features for the model submitted by the vehicle manufacturer.
2.19	<b>Vehicle for Conformity of Production:</b> Means a vehicle selected at random from a production series of vehicle model which has already been type approved.
2.20	<p><b>Evaporative emissions</b> means the hydrocarbon vapors lost from the fuel system of a motor vehicle other than those from tailpipe emissions.</p> <ol style="list-style-type: none"> <li>I. Tank breathing losses are hydrocarbon emissions caused by temperature changes in the fuel tank (assuming a ratio of C1H2.33).</li> <li>II. Hot soak losses are hydrocarbon emissions arising from the fuel system of a stationary vehicle after a period of driving (assuming a ratio of C1 H2.20).</li> </ol>
2.21	<b>Engine crankcase</b> : means the spaces in, or external to, an engine which are connected to the oil sump by internal or external ducts through which gases and vapors can escape.

2.22	<b>OBD an on-board diagnostic system</b> means an electronic system fitted on-board of a vehicle that has the capability of identifying the likely area of malfunction by means of fault codes stored in a computer memory which can be accessed by means of a generic scan tool;
3	<b>Application for Type Approval :</b>
3.1	The application for type approval of a vehicle model with regard to limitation of tail pipe emissions, Idling emission, crankcase emission evaporative emissions, durability (if opted by manufacturer) and the on-board diagnostic (OBD-I) system of the vehicles shall be submitted by the vehicle manufacturer with a description of the engine and vehicle model comprising all the particulars referred to in Chapter 2 of this part. A vehicle representative of the vehicle model to be type approved shall be submitted to the testing agency responsible for conducting tests referred in para. 5 of this Chapter.
4.	<b>Type Approval :</b>
	If the vehicle submitted for type approval pursuant to these rules, meet the requirements of para 5 below, approval of that vehicle model shall be granted. The approval of the vehicle model pursuant to this part shall be communicated to the vehicle manufacturer and nodal agency by the testing agency in the form of certificate of compliance to the CMVR, as envisaged in Rule-126 of CMVR.
5	<b>Specification and Tests :</b>
5.1	General: The components liable to affect the tailpipe emissions of gaseous pollutants shall be so designed, constructed and assembled to enable the vehicle, in normal use, despite the vibrations to which they may be subjected to comply with the provisions of this rule
5.2	Specifications concerning the emissions of pollutants
5.2.1	The vehicle shall be subjected to tests of Type I, II, III, IV, V and Engine Power test as specified below.
5.2.2	<b>Type I Test: (Verifying the average tailpipe emissions)</b>
5.2.2.1	The vehicle shall be placed on a Chassis dynamometer bench equipped with a means of load and inertia simulation.
5.2.2.2	A test lasting a total of 1170 seconds and comprising of six cycles as described in Chapter 3 of this part shall be carried out, without interruption. The cold phase means the first 195 s (one elementary urban cycle) after cold start of the propulsion. The warm phase is the last 975 s (five elementary urban cycles), when the propulsion is further warming up and finally running at operating temperature. The weighting factors for cold and warm phases during calculation purpose shall be as per 6.3 of Chapter 8 of this part. Vehicles that are fuelled with LPG or NG shall be tested in the type I test for variations in the composition of LPG or NG, as set out in notification, vehicles that can be fuelled either with LPG or NG to

	<p>be tested for Fuel A &amp; Fuel B in case of LPG and G20 &amp; G25 in case of NG.</p> <p>Until availability of reference LPG (fuel A &amp; fuel B), CNG(G20,G25)) as per notification, CNG/LPG vehicles will be tested as per commercially available CNG/LPG fuels as per guidelines given by Government of India.</p>
5.2.2.3	<p>During the test the exhaust gases shall be diluted with air and a proportional sample collected in one or more bags. The contents of the bags will be analysed at the end of the test. The total volume of the diluted exhaust shall be measured. Carbon monoxide (CO), hydro carbon (HC) and nitrogen oxide emissions (NO<sub>x</sub>), and in addition particulate matter (PM) the case of vehicles equipped with compression ignition engines shall be recorded. Carbon dioxide shall also be recorded for the purpose of calculation of fuel consumption.</p>
5.2.2.4	<p>The test shall be carried out by the procedure described in Chapter 3 of this part . The methods used to collect and analyse the gases and to remove and weigh the particulates shall be as prescribed.</p>
5.2.2.5	<p>Subject to the provisions of the paragraphs 5.2.2.7 &amp; 5.2.2.8, the test shall be repeated three times, the test results shall be multiplied by appropriate deterioration factors as notified in CMVR. The resulting masses of gaseous emission and, in the case of vehicles equipped with compression-ignition engines, the mass of particulates obtained in each test shall not exceed the applicable limits.</p>
5.2.2.6	<p>Type Approval Mass Emission Standards for Type I test:</p>
5.2.2.6.1	<p>Emission Limit values for Qudricycle shall be as specified in gazette notification vehicles operating on compressed natural gas mode,the provisions of rule115-B shall be applicable.For vehicles operating on liquefied petroleum gas mode,the provisions of rule115-C shall be applicable.</p>
5.2.2.7	<p>Nevertheless, for each of the pollutants or combination of pollutants one of the three results obtained may exceed by not more than 10% of the applicable limits prescribed for the vehicle concerned, provided the arithmetical mean of the three results is not exceeding the prescribed limit. Where the prescribed limits are exceeded for more than one pollutant or combination of pollutants, it shall be immaterial whether this occurs in the same test or in different tests.</p>
5.2.2.8	<p>The number of tests prescribed in Para 5.2.2.7 above shall be reduced in the conditions hereinafter defined, where V<sub>1</sub> is the result of the first test and V<sub>2</sub> the result of the second test for each of the pollutants referred to in Para 5.2.2.5 above.</p>
5.2.2.8.1	<p>Only one test shall be performed if the result obtained for each pollutant is less than or equal to 0.7 L i.e.  <math>V_1 \leq 0.70 \text{ L}</math>.</p>

5.2.2.8.2 If the requirements of 5.2.2.8.1 is not satisfied, only two tests are performed if for each pollutant, the following requirements are met.  
 $V_1 \leq 0.85 L$  and  $V_1 + V_2 \leq 1.7 L$  and  $V_2 < L$

**Figure 1 : Flow Sheet for the Type Approval Test**

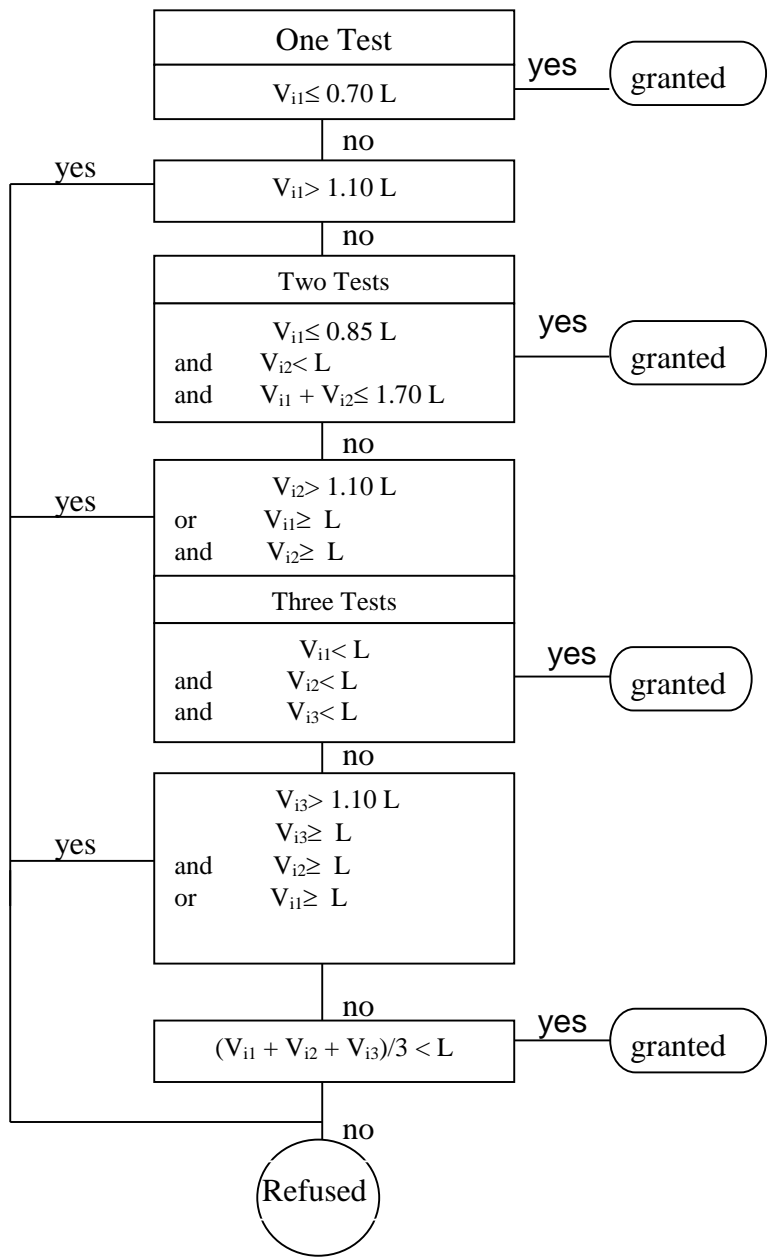

5.2.3	Type II Test (Test for carbon monoxide and Hydrocarbons emissions at idling speed)
5.2.3.1	This is applicable only for spark ignition engined vehicles
5.2.3.2	The carbon monoxide and Hydrocarbons content by volume of the exhaust gases emitted with the engine idling must not exceed as per the limits mentioned in Notification clause (i) of sub-rule (2) of rule 115 as applicable.  For Petrol driven vehicles, the carbon monoxide content by volume of the exhaust gases emitted with the engine and Lambda at High Idle with 2500±200 rpm must not exceed 0.2 % of CO & 1 ± 0.03 Lambda or as declared by the vehicle manufacturer
5.2.3.3	For Diesel vehicles, Free acceleration Smoke test to be carried out as defined in Chapter IV of PART IV and shall meet Limit values as per clause (ii) of sub-rule(2) of rule 115 as applicable.
5.2.4	<b>Type III test (Control of crankcase emission gases) :</b>  The crank case breather shall be connected to the Intake system in the case of spark ignition four stroke engines, so that there is no escape of crank case gases into atmosphere. This requirement is not applicable for compression ignition vehicles.
5.2.5	<b>Type IV test (determination of evaporative emission).</b>
5.2.5.1	This test shall be carried out on all petrol driven Quarcycle vehicles. This procedure is not applicable to Bi fuel vehicle (Limp home mode) (i.e. LPG/CNG and Petrol), where the petrol tank capacity does not exceed Three litres.
5.2.5.2	When tested in accordance with Chapter 11, evaporative emission shall be less than 2 g/test.
5.2.6	<b>Type V test (durability of anti-pollution devices)</b>
5.2.6.1	The requirement of durability must be compiled on all quadricycles vehicles. This may be established by using the deterioration factor notified in CMVR or by carrying out the durability test. The test represents an ageing test of 80000 km driven in accordance with the program described in chapter 10, on a test track, on the road or on a chassis dynamometer.
5.2.6.2	At the request of the manufacturer, the testing agency may carry out the Type I test before Type V test has been completed using the deterioration factors given in Notification. On completion of Type V test, the testing agency may then amend the type-approval results recorded in the Notification with those measured in type V test.
5.2.6.3	Deterioration factor are determined using either procedure in chapter 10 or using the values in the notifications at the option of manufacturer. The factors are used to establish compliance with the requirements of 5.2.2.5 and 8.2
6.	<b>Modifications of the vehicle Model :</b>



6.1	Every modification in the essential characteristics of the vehicle model shall be intimated by the vehicle manufacturer to the test agency which type approved the vehicle model. The test agency may either:
6.1.1	Consider that the vehicle with the modifications made may still comply with the requirement, or Require a further test to ensure further compliance.
6.2	In case of 6.1.1 above, the testing agency shall extend the type approval covering the modified specification or the vehicle model shall be subjected to necessary tests. In case, the vehicle complies with the requirements, the test agency shall extend the type approval.
6.3	Any changes to the procedure of PDI and running in concerning emission shall also be intimated to the test agency by the vehicle manufacturer, whenever such changes are carried out.
7	<b>Model Changes (Type I &amp; Type II test) :</b>
7.1	<b>Vehicle models of Different Reference Weights and coast down coefficients:</b>
	Approval of a vehicle model may under the following conditions be extended to vehicle models which differ from the type approved only in respect of their reference weight.
7.1.1	Approval may be extended to vehicle model of a reference weight requiring merely the use of the next one higher or any lower equivalent inertia.
7.1.2	If the reference weight of the vehicle model for which extension of the type approval is requested requires the use of a flywheel of equivalent inertia lower than that used for the vehicle model already approved, extension of the type approval shall be granted if the masses of the pollutants obtained from the vehicle already approved are within the limits prescribed for the vehicle for which extension of the approval is requested.
7.1.3	If different body configurations are used with the same power plant and drive line and the change in the load equation due to changes in the coefficient of resistances that is within the limits that would be caused by the change of inertia as permitted by Clause 7.1.1 above the approval may be extended.
7.2	<b>Vehicle models with Different Overall Gear Ratios</b>
7.2.1	Approval granted to a vehicle model may under the following conditions be extended to vehicle models differing from the type approved only in respect of their overall transmission ratios;
7.2.1.1	For each of the transmission ratios used in the Type I Test, it shall be necessary to determine the proportion $E = (V_2 - V_1)/V_1$ , where $V_1$ and $V_2$ are respectively the speed at 1000 rev/min of the engine of the vehicle model type approved and the speed of the vehicle model for which extension of the approval is requested.

7.2.2	If for each gear ratio $E \leq 8\%$ , the extension shall be granted without repeating the Type I Tests.
7.2.3	If for at least one gear ratio, $E > 8\%$ and if for each gear ratio $E \leq 13\%$ the Type I test must be repeated, but may be performed in laboratory chosen by the manufacturer subject to the approval of the test agency granting type approval. The report of the tests shall be submitted to the test agency by the manufacturer.
7.3	<b>Vehicle models of Different Reference Weights, coefficient of coast down and Different Overall Transmission Ratios</b>
7.3.1	Approval granted to a vehicle model may be extended to vehicle models differing from the approved type only in respect of their reference weight, coefficient of coast down and their overall transmission ratios, provided that all the conditions prescribed in Para 7.1 and 7.2 above are fulfilled.
7.4	<b>Note :</b> When a vehicle type has been approved in accordance with the provisions of Para 7.1 to 7.3 above, such approval may not be extended to other vehicle types.
7.5	<b>Vehicle model with different makes of emission related components :</b>
7.5.1	The names of suppliers of items such as ignition coil, magneto, CB point, air filter, silencer, etc. mentioned above, the manufacturers shall inform the test agency that In addition to carried out the type approval, the names of new alternate suppliers for these items as and when they are being introduced.
7.5.2	At the time of first type approval or for a subsequent addition of a make for a particular part, work out the combinations of tests in such a way that each make of such parts are tested at least once.
7.6	<b>Crank Case Emission (type III test) &amp;Evaporative Emissions (type IV test)</b>
7.6.1	Approval granted to a vehicle type equipped with a control system for evaporative emissions may be extended under the following conditions.  Test types III and IV ('X' in Table 1 means 'applicable')

Table: 1

Sr. No.	Classification criteria description	Test type III	Test type IV
1.	Vehicle		
1.1.	Category;	X	X
1.2.	Sub category;		X
2.	System		
2.1.	Propulsion (not) equipped with crankcase ventilation system;	X	
2.1.1.	Crankcase ventilation system type;	X	
2.1.2.	Operation principle of crankcase ventilation system(breather/vacuum/overpressure);	X	
2.2.	Propulsion (not) equipped with evaporative emission Controlsystem;		X
2.2.1.	Evaporative emission control system type;		X
2.2.2.	Operation principle of evaporative emission control System (active/passive/mechanically or electronically controlled);		X

	2.2.3.	Identical basic principle of fuel/air metering (e.g.carburettor/single point injection/multi point injection/engine speed density through MAP/ massairflow);		X
	2.2.4.	Identical material of the fuel tank and liquid fuel hoses is identical;		X
	2.2.5.	The fuel storagevolume is with in a range of+/- 50%;		X
	2.2.	The setting of the fuel storage relief valve is identical;		X
	2.2.6.	Identical method of storage of the fuel vapour (i.e.trap for mand volume, storage medium,air cleaner(if used for evaporative emission control) etc.);		X
	2.2.7.	Identical method of purging of the stored vapour (e.g.airflow,purgevolumeoverthe driving cycle);		X
	2.2.8.	Identical method of sealing and venting of the fuel metering system;		X
<b>7.7</b>	<b>Durability of anti-pollution devices (Type V test)</b>			
7.7.1	Approval granted to a vehicle type may be extended to different vehicle types, provided that the engine/pollution control system combination is identical to that of the vehicle already approved. To this end, those vehicle types whose parameters described below are identical or remain within the limit values prescribed are considered to belong to the same engine/pollution control system combination.			
7.7.1.1	<p>Engine:</p> <ul style="list-style-type: none"> <li>- number of cylinders,</li> <li>- engine capacity (<math>\pm 15\%</math>)</li> <li>- configuration of the cylinder block,</li> <li>- number of valves,</li> <li>- fuel system</li> <li>- type of cooling system</li> <li>- combustion process</li> <li>- cylinder bore center to center dimensions</li> </ul>			
7.7.1.2	<p>Pollution control system :</p> <p>Catalytic Converters:</p> <ul style="list-style-type: none"> <li>- Number of catalytic converters and elements</li> </ul>			

	<ul style="list-style-type: none"> <li>- Size and shape of catalytic converters (volume of monolith <math>\pm</math> 10%),</li> <li>- Type of catalytic activity (oxidizing, three-way)</li> <li>- Precious metal load (identical or higher),</li> <li>- Precious metal ratio (+/-15%)</li> <li>- Substrate (structure and material),</li> <li>- Cell density,</li> <li>- Type of casing for the catalytic converter(s),</li> <li>- Location of catalytic converters (position and dimension in the exhaust system, that does not produce a temperature variation of more than 50 K at the inlet of the catalytic converter). This temperature variation shall be checked under stabilized conditions at a speed 43 km/h and the load setting of type I test.</li> </ul> <p>Air injection :</p> <ul style="list-style-type: none"> <li>- With or without</li> <li>- Type (pulsair, air pumps....)</li> <li>- EGR: <ul style="list-style-type: none"> <li>o With or without</li> </ul> </li> </ul>
7.7.1.3	Inertia category :The two inertia categories immediately above and any inertia category below.
7.7.1.4	The durability test may be achieved by using a vehicle, the body style, gear box (automatic or manual) and size of the wheels or tyres of which are different from those of the vehicle type for which the type approval is sought.
7.8	On-board diagnostics approval granted to a vehicle type with respect to the OBD system may be extended to different vehicle types belonging to the same vehicle-OBD family as described in Chapter 12, Annex 3 as applicable.
8	<b>Conformity of Production :</b>
8.1	Every produced vehicle of the model approved under this rule shall conform, with regard to components affecting the emission of gaseous pollutants by the engine to the vehicle model type approved. The administrative procedure for carrying out conformity of production is given in Part VI of this document.For Type IV shall be as per para 7, Annexure 1, Chapter 11 of this part.
8.2	Type I Test: Verifying the average emission of gaseous pollutants : For verifying the conformity of production in a Type I Test, the following procedure as per Option1 is adopted.
8.2.1	To verify the average tailpipe emissions of gaseous pollutants of low volume vehicleswith Annual production less than 250 per 6 months, manufacture can choose from the Option 1 or Option 2 as listed below:
8.3	<b>Option 1</b>

8.3.1	The vehicle samples taken from the series, as described in 8.1 is subjected to the single test described in para 5.2.2 above. The results shall be multiplied by the deterioration factors used at the time of type approval. The result masses of gaseous emissions and in addition in case of vehicles equipped with compression ignition engines, the mass of particulates obtained in the test shall not exceed the applicable limits.
8.3.2	Procedure for Conformity of Production as per Bharat Stage- IV L7 (quadricycle) category vehicles
8.3.3	Conformity of production shall be verified as per Bharat Stage IV emission norms for L7 (quadricycle) category vehicles
8.3.3.1	as given in para 5.2.2.6.1 and with the procedure given below.
8.3.3.2	To verify the average tailpipe emissions of gaseous pollutants following procedure shall be adopted
8.3.3.3	Minimum of three vehicles shall be selected randomly from the series with a sample lot size as defined in part VI of MoSRT/CMVR/TAP-115/116.
8.3.3.4	After selection by the authority, the manufacturer must not undertake any adjustments to the vehicles selected, except those permitted in Part VI.
8.3.3.5	All three randomly selected vehicles shall be tested for a Type -1 test as per Para 5.2.2 of chapter 1 of this part.
8.3.3.6	Let $X_1, X_2$ & $X_3$ are the test results for the Sample No.1, 2 & 3.
8.3.3.7	<p>If the natural Logarithms of the measurements in the series are <math>X_1, X_2, X_3, \dots, X_j</math> and <math>L_i</math> is the natural logarithm of the limit value for the pollutant, then define :</p> $d_j = X_j - L_i$ $\bar{d}_n = \frac{1}{n} \sum_{j=1}^n d_j$ $V_n^2 = \frac{1}{n} \sum_{j=1}^n (d_j - \bar{d}_n)^2$
8.3.3.8	<p>Table I of Chapter 1 of this part shows values of the pass (<math>A_n</math>) and fail (<math>B_n</math>) decision numbers against current sample number. The test statistic is the ratio <math>\bar{dn} / V_n</math> and must be used to determine whether the series has passed or failed as follows :</p> <ul style="list-style-type: none"> <li>- Pass the series, if <math>\bar{dn} / V_n \leq A_n</math> for all the pollutants</li> <li>- Fail the series if <math>\bar{dn} / V_n \geq B_n</math> for any one of the pollutants - Increase the sample size by one, if <math>A_n &lt; \bar{dn} / V_n &lt; B_n</math> for any one of the pollutants. - If no pass decision is reached for all the pollutants and no fail decision is reached for one pollutant, a test shall be carried out on another randomly selected sample till a pass or fail decision is arrived at.</li> </ul>

**Figure 2 :  
Option I : COP Test Procedure**

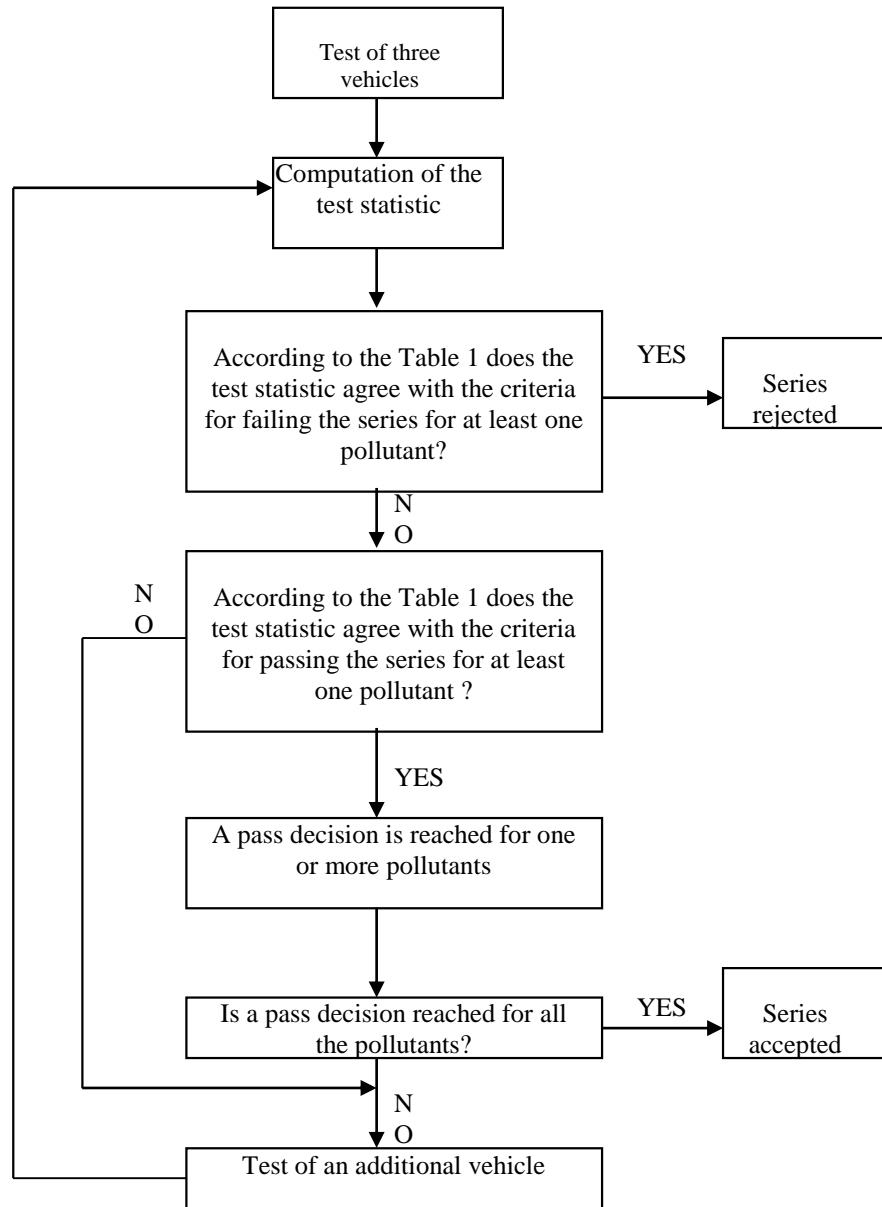

Table I : Applicable for COP Procedure

Sample size (n)	Pass decision threshold ( $A_n$ )	Fail decision threshold ( $B_n$ )
3	-0.80381	16.64743
4	-0.76339	7.68627
5	-0.72982	4.67136
6	-0.69962	3.25573
7	-0.67129	2.45431
8	-0.64406	1.94369
9	-0.61750	1.59105
10	-0.59135	1.33295
11	-0.56542	1.13566
12	-0.53960	0.97970
13	-0.51379	0.85307
14	-0.48791	0.74801
15	-0.46191	0.65928
16	-0.43573	0.58321
17	-0.40933	0.51718
18	-0.38266	0.45922
19	-0.35570	0.40788
20	-0.32840	0.36203
21	-0.30072	0.32078
22	-0.27263	0.28343
23	-0.24410	0.24943
24	-0.21509	0.21831
25	-0.18557	0.18970
26	-0.15550	0.16328
27	-0.12483	0.13880
28	-0.09354	0.11603
29	-0.06159	0.09480
30	-0.02892	0.07493
31	0.00449	0.05629
32	0.03876	0.03876



8.4	<b>Option 2</b>
8.4.1	Minimum of three vehicles shall be selected randomly from the series with a sample lot size.
8.4.2	After selection by the authority, the manufacturer must not undertake any adjustments to the vehicles selected, except those permitted in Part VI, MoRTH/CMVR/TAP-115/116
8.4.3	First vehicle out of three randomly selected vehicles shall be tested for Type - I test as per MoRTH/CMVR/TAP-115/116 Para 5.2.2 of chapter 1.
8.4.4	Only one test ( $V_1$ ) shall be performed if the test results for all the pollutants meet 70 % of their respective limit values (i.e. $V_1 \leq 0.7L$ & L being the COP Limit)
8.4.5	Only two tests shall be performed if the first test results for all the pollutants doesn't exceed 85% of their respective COP limit values (i.e. $V_1 \leq 0.85L$ ) and at the same time one of these pollutant value exceeds 70% of the limit (i.e. $V_1 > 0.7L$ ) In addition, to reach the pass decision for the series, combined results of $V_1$ & $V_2$ shall satisfy such requirement that : $(V_1 + V_2) < 1.70 L$ and $V_2 \leq L$ for all the pollutants.
8.4.6	Third Type - I ( $V_3$ ) test shall be performed if the para 4.11 above doesn't satisfy and if the second test results for all pollutants are within the 110% of the prescribed COP limits, Series passes only if the arithmetical mean for all the pollutants for three type I tests doesn't exceed their respective limit value. (i.e. $(V_1 + V_2 + V_3)/3 \leq L$ )
8.4.7	If one of the three test results obtained for any one of the pollutants exceed 10% of their respective limit values the test shall be continued on Sample No. 2 & 3 as given in the Figure - 2 of chapter 1 of this part, as the provision for extended COP and shall be informed by the test agency to the nodal agency.
8.4.8	These randomly selected sample No.2 & 3 shall be tested for only one Type - I test as per para 5.2.2. of Chapter 1 of this part.
8.4.9	Let $X_2$ & $X_3$ are the test results for the Sample No.2 & 3 and $X_1$ is the test result of the Sample No.1 which is the arithmetical mean for the three type - I tests conducted on Sample No. 1
8.4.10	If the natural Logarithms of the measurements in the series are $X_1, X_2, X_3, \dots, X_j$ and $L_i$ is the natural logarithm of the limit value for the pollutant, then define : $d_j = X_j - L_i$ $d_n = \frac{1}{n} \sum_{j=1}^n d_j$ $V_n^2 = \frac{1}{n} \sum_{j=1}^n (d_j - \bar{d}_n)^2$
8.4.11	Table I of this part shows values of the pass ( $A_n$ ) and fail ( $B_n$ ) decision numbers against current sample number. The test statistic

	<p>is the ratio <math>\bar{d}_n / V_n</math> and must be used to determine whether the series has passed or failed as follows :-</p> <ul style="list-style-type: none"> <li>• Pass the series, <math>d_n / V_n \geq A_n</math> for all the pollutants-</li> <li>• Fail the series <math>d_n / V_n \geq B_n</math> for any one of the pollutants.-</li> <li>• Increase the sample size by one, if <math>A_n &lt; d_n / V_n \leq B_n</math> for any one of the pollutants.</li> </ul>
8.4.12	If no pass decision is reached for all the pollutants and no fail decision is reached for one pollutant, a test shall be carried out on another randomly selected sample till a pass or fail decision is arrived at.
8.5	All these tests shall be conducted with the reference fuel as specified in the applicable gazette notification. However, at the manufacturer's request, tests may be carried out with commercial fuel.
8.6	Type II Test : Carbon-monoxide and Hydrocarbons emission at idling speed and Carbon-monoxide & Lambda at High Idle speed .When the vehicle taken from the series for the first type I test mentioned in 8.2 para above, subjected to the test described in Chapter 9 of this Part for verifying the carbon monoxide and hydrocarbon emission at idling speed should meet the limit values specified in para 5.2.3.2 above. If it does not, another 10 vehicles shall be taken from the series at random and shall be tested as per Chapter 9 of this Part. These vehicles can be same as those selected for carrying out Type I test. Additional vehicles if required, shall be selected for carrying out for Type II test. At least 9 vehicles should meet the limit values specified in para 5.2.3.2 above. Then the series is deemed to conform.
8.7	Free acceleration smoke test : For Diesel vehicles shall comply with the provision of clause (ii) of sub-rule (2) of rule 115 as applicable. If it does not then procedure to be followed as per chapter 1 of Part IV of CMVR/TAP/115-116 , issue 4. As amended time to time.

**Figure 3**  
**OPTION II : COP Test Procedure**

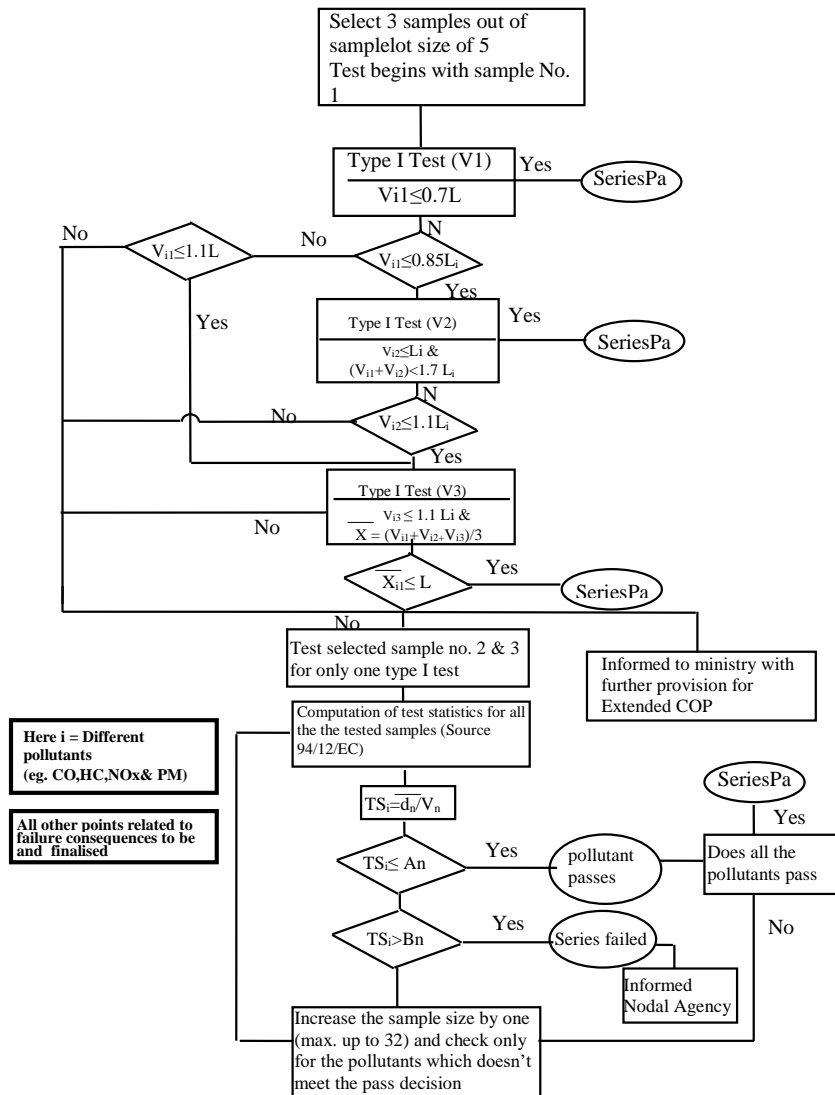

## Chapter 2

### ESSENTIAL CHARACTERISTICS OF THE VEHICLE AND ENGINE AND INFORMATION CONCERNING THE CONDUCT OF TESTS

Information is to be provided as per AIS-007 as amended from time to time

<b><u>Chapter 3</u></b>	
<b><u>TYPE I TEST ON S.I. ENGINES, CNG, LPG AND DIESEL ENGINED VEHICLE (VERIFYING THE AVERAGE TAILPIPE EMISSION) OF GASEOUS AND PARTICULATE POLLUTANTS</u></b>	
1	This chapter describes the procedure for the Type I test defined in paragraph 5.2.2 of Chapter 1 of this Part. This chapter should be read in conjunction with applicable Gazette Notification under CMVR for which the test is to be carried out.
2	<b>Operating Cycle on the Chassis Dynamometer :</b>
2.1	Description of the Cycle : The operating cycle on the chassis dynamometer shall be as given in 2.1.1 as applicable.
2.1.1	The operating cycle on the chassis dynamometer and breakdown of the cycle shall be that indicated in Table I-(A) and depicted in Figure 1-(A) of this Chapter at the choice by vehicle manufacturer
2.2	General Conditions under which the cycle is carried out : preliminary testing cycles should be carried out if necessary to determine how best to actuate the accelerator and brake controls so as to achieve a cycle approximately to the theoretical cycle within the prescribed limits
2.2.1	Use of the Gear Box : The use of the gearbox on chassis dynamometer shall be in accordance with Para 2.2.2 of this Chapter.
2.2.2	Use of the Gear Box: The use of the gear box shall be as specified by the manufacturer. However, in the absence of such instructions, the following points shall be taken into account.:
2.2.2.1	<b>Manual Change Gear Box :</b>
2.2.2.1.1	During each phase at constant speed, the rotating speed of the engine shall be, if possible, between 50 and 90% of the speed corresponding to the maximum power of the engine. When this speed can be reached in two or more gears, the vehicle shall be tested with the higher gear engaged.
2.2.2.1.2	During acceleration, the vehicle shall be tested in whichever gear is appropriate to the acceleration imposed by the cycle. A higher gear shall be engaged at the latest when the rotating speed is equal to 110% of the speed corresponding to the maximum power of the engine.
2.2.2.1.3	During deceleration, a lower gear shall be engaged before the engine starts to idle roughly, at the latest when the engine revolutions are equal to 30% of the speed corresponding to the maximum power of the engine. No change down to first gear shall be effected during deceleration.
2.2.2.1.4	Vehicles equipped with an overdrive which the driver can actuate shall be tested with the overdrive out of action.
2.2.2.1.5	When it is not possible to adhere to the cycle, the operating cycle will be modified for gear change points, allowing 2 seconds time interval at constant speed for each gear change keeping the total time constant.

	Table I-(A) and Figure 1-(A) of this chapter shows the operating cycle with recommended gear positions.
2.2.2.2	Automatic Gear Box : Vehicles equipped with automatic shift gear boxes shall be tested with the highest gear (drive) engaged. The accelerator shall be used in such a way as to obtain the steadiest acceleration possible, enabling the various gears to be engaged in the normal order.
2.3	<b>Tolerances</b>
2.3.1	A tolerance of $\pm 1$ km/h shall be allowed between the indicated speed and the theoretical speed during acceleration, during steady speed and during deceleration, when the vehicle's brakes are used. If the vehicle decelerates more rapidly without the use of the brakes, then the timing of the theoretical cycle shall be restored by constant speed or idling period merging into the following operation. Speed tolerances greater than those prescribed shall be accepted, during phase changes provided that the tolerances are never exceeded for more than 0.5 second on any one occasion.
2.3.2	Time tolerances of $\pm 0.5$ second shall be allowed. The above tolerances shall apply equally at the beginning and at the end of each gear changing period.
2.3.3	The speed and time tolerances shall be as indicated in Figure 1-(A) of this chapter.
3	<b>Vehicle and Fuel</b>
3.1	<b>Test Vehicle :</b>
3.1.1	The vehicle presented shall be checked that it is the same model as specified as per format of chapter 2 of this Part. It shall have been run-in either as per manufacturer's specification or at least 1000 kms before the test.
3.1.2	The exhaust device shall not exhibit any leak likely to reduce the quantity of gas collected, and this shall be the same emerging from the engine.
3.1.3	The air intake system should be leak proof.
3.1.4	The settings of the engine and of the vehicle's controls shall be those prescribed by the manufacturer. This requirement also applies, in particular, to the settings for idling and for the cold start device, automatic choke, and exhaust gas cleaning systems, etc.The vehicle to be tested, or an equivalent vehicle, shall be fitted, if necessary with a device to permit the measurement of characteristic parameters necessary for the chassis dynamometer setting.
3.1.5	The testing agency may verify that the vehicle conforms to the performance of power, acceleration, maximum speed etc.,stated by the manufacturer and that it can be used for normal driving and more particularly that it is capable of starting when cold and when hot.
3.2	<b>Fuel :</b> The reference fuel as prescribed in the applicable Gazette notification shall be used. If the engine is lubricated by a fuel oil mixture, the oil added to reference fuel shall comply as to grade and quantity with the manufacturer's recommendation. Until availability of reference LPG (Fuel A& Fuel B), CNG (G20, G25) as per Notification, CNG, LPG

	vehicles will be tested as per commercially available CNG/LPG fuels as per guidelines given GOI.
4	<b>Test Equipment :</b>
4.1	<b>Chassis Dynamometer :</b>
4.1.1	The dynamometer must be capable of simulating road load with adjustable load curve, i.e. a dynamometer with at least two road load parameters that can be adjusted to shape the load curve.
4.1.2	The chassis dynamometer may have one or two rollers. In the case of a single roller, the roller diameter shall not be less than 400 mm.
4.1.3	The setting of the dynamometer shall not be affected by the lapse of time. It shall not produce any vibrations perceptible to the vehicle and likely to impair the vehicle's normal operations.
4.1.4	It shall be equipped with means to simulate inertia and load. These simulators shall be connected to the front roller, in the case of a two roller dynamometer.
4.1.5	The roller shall be fitted with a revolution counter with reset facility to measure the distance actually covered.
4.1.6	<b>Accuracy :</b>
4.1.6.1	It shall be possible to measure and read the indicated load to an accuracy of $\pm 5$ percent.
4.1.6.2	In the case of a dynamometer with an adjustable load curve, the accuracy of matching dynamometer load to road load shall be within 5 per cent at 50, 40, 30 km/h and 10 percent at 20 km/h. Below this, the dynamometer absorption must be positive.
4.1.6.3	The total equivalent inertia of the rotating parts (including the simulated inertia where applicable) must be known and within $\pm 20$ kg of the inertia class for the test.
4.1.6.4	The speed of the vehicle shall be measured by the speed of rotation of the roller (the front roller in the case of a two roller dynamometer). It shall be measured with an accuracy of $\pm 1$ km/h at speeds above 10 km/h.
4.1.7	<b>Load and Inertia Setting :</b>
4.1.7.1	Dynamometer with adjustable load curve: the load simulator shall be adjusted in order to absorb the power exerted on the driving wheels at various steady speeds of 50, 40, 30 and 20 km/h.
4.1.7.2	The means by which these loads are determined and set are described in Chapter 4 of this Part.
4.1.7.3	Chassis Dynamometers with electrical inertia simulation must be demonstrated to be equivalent to mechanical inertia systems. The means by which equivalence is established is described in Chapter 5 of this Part.
4.1.7.4	The running resistance force for the chassis dynamometer settings can be derived either from coast-down measurements described in Chapter 4 of this part or from a running resistance values specified in Table III of this chapter, with reference to Appendix 5 of this chapter.
4.1.8	<b>Chassis Dynamometer Calibration :</b>

4.1.8.1	The dynamometer should be calibrated periodically as recommended by the manufacturer of the chassis dynamometer and then calibrated as required. The calibration shall consist of the manufacturers' recommended procedure and a determination of the dynamometer frictional power absorption at 40 km/h when being used for testing of L7 (quadricycle) category vehicles. One method for determining this is given in Chapter 7. Other methods may be used if they are proven to yield equivalent results.
4.1.8.1.1	The performance check consists of conducting dynamometer coast down time at one or more inertia power setting and comparing the coast down time to that recorded during the last calibration. If the coast down time differs by more than 1 second, a new calibration is required.
4.2	<b>Exhaust Gas-sampling System :</b>
4.2.1	The exhaust gas-sampling shall be designed to enable the measurement of the true mass emissions of vehicle exhaust. A Constant Volume Sampler System (CVS) wherein the vehicle exhaust is continuously diluted with ambient air under controlled conditions should be used. In the constant volume sampler concept of measuring mass emissions, two conditions must be satisfied -the total volume of the mixture of exhaust and dilution air must be measured and a continuously proportional sample of the volume must be collected for analysis. Mass emissions are determined from the sample concentrations, corrected for the pollutant content of the ambient air and totalized flow, over the test period. The particulate pollutant emission level is determined by using suitable filters to collect the particulates from a proportional part flow throughout the test and determining the quantity thereof gravimetrically in accordance with 4.3.2.
4.2.2	The flow through the system shall be sufficient to eliminate water condensation at all conditions which may occur during a test, as defined in Chapter 6 of this part.
4.2.3	Figure 5, 6, and 7 of Chapter 6 of this Part gives a schematic diagram of the general concept. Examples of three types of Constant Volume Sampler systems which will meet the requirements are given in Chapter 6 of this part.
4.2.4	The gas and air mixture shall be homogenous at point S2 of the sampling probe.
4.2.5	The probe shall extract a true sample of the diluted exhaust gases.
4.2.6	The system should be free of gas leaks. The design and materials shall be such that the system does not influence the pollutant concentration in the diluted exhaust gas. Should any component (heat exchanger, blower, etc.) change the concentration of any pollutant gas in the diluted gas, then the sampling for that pollutant shall be carried out before that component, if the problem cannot be corrected.
4.2.7	If the vehicle being tested is equipped with an exhaust pipe comprising several branches, the connection tubes shall be connected as near as possible to the vehicle



4.2.8	Static pressure variations at the tail pipe(s) of the vehicle shall remain within $\pm 1.25$ kPa of the static pressure variations measured during the dynamometer driving cycle and with no connection to the tailpipe(s). Sampling systems capable of maintaining the static pressure to within $\pm 0.25$ kPa will be used if a written request from a manufacturer to the authority granting the approval substantiates the need for the closer tolerance. The back-pressure shall be measured in the exhaust pipe as near as possible to its end or in an extension having the same diameter.
4.2.9	The various valves used to direct the exhaust gases shall be of a quick-adjustment, quick-acting type.
4.2.10	The gas samples shall be collected in sample bags of adequate capacity. These bags shall be made of such materials as will not change the pollutant gas by more than $\pm 2\%$ after twenty minutes of storage.
4.3	<b>Analytical Equipment :</b>
4.3.1	Pollutant gases shall be analysed with the following instruments :
4.3.1.1	Carbon monoxide (CO) and carbon dioxide (CO <sub>2</sub> ) analysis. The carbon monoxide and carbon dioxide analysers shall be of the Non-Dispersive Infra Red (NDIR) absorption type.
4.3.1.2	Hydrocarbon (HC) analysis - Gasoline Vehicles. The hydrocarbons analyser shall be of the Flame Ionisation (FID) type calibrated with propane gas expressed equivalent to carbon atoms.
4.3.1.3	Hydrocarbons (HC) analysis - Diesel Vehicles. The hydrocarbon analyser shall be of the Flame Ionisation type Detector with valves , pipe work etc. heated to $463 \text{ K} \pm 10 \text{ K}$ (HFID). It shall be calibrated with propane gas expressed equivalent to carbon atoms (C1 ).
4.3.1.4	Nitrogen oxide (NO <sub>x</sub> ) analysis. The nitrogen oxide analyser shall be of the Chemiluminescent (CLA) type with an NO <sub>x</sub> -NO converter or by NDUVR (non- dispersive ultraviolet resonance absorption) type analyser.
4.3.1.5	<p>2.1.1.1 Particulates : Gravimetric determination of the particulates collected. These particulates are in each case collected by two series mounted filters in the sample gas flow. The quantity of particulates collected by each pair of filters shall be as follows :</p> <p><math>V_{ep}</math> : Flow through filters.  <math>V_{mix}</math> : Flow through tunnel.  <math>M</math> : Particulate mass (g/km)  <math>M_{limit}</math> : Limit mass of particulates (limit mass in force, g/km)  <math>m</math> : Mass of particulates collected by filters (g)  <math>d</math> : Actual distance corresponding to the operating cycle (km)</p> $M = \frac{(V_{mix} * m)}{(V_{ep} * d)} \quad \text{or}$

	$m = \frac{(M * d * V_{ep})}{V_{mix}}$ $M = \frac{V_{mix} * m}{V_{ep} * d}$ <p>The particulate sample rate (<math>V_{ep} / V_{mix}</math>) will be adjusted so that for</p> <p><math>M = M_{limit} \leq m \leq 5 \text{ mg}</math> (when 47mm diameter filters are used).</p> <p>The filter surface consist of a material that is hydrophobic and inert towards the components of exhaust gas (flurocarbon coated glass fibre filters or equivalent)</p>
4.3.1.6	<p><b>Accuracy</b></p> <p>The analysers must have a measuring range compatible with the accuracy required to measure the concentrations of the exhaust gas sample pollutants. Measurements error must not exceed <math>\pm 2\%</math> (intrinsic error of analyser) disregarding the true value for the calibration gases. For concentration of less than 100 ppm the measurement error must not exceed <math>\pm 2</math> ppm. The ambient air sample must be measured on the same analyser with an appropriate range.</p> <p>The microgram balance used to determine the weight of all filters must have an accuracy of 5 ug and readability of 1 ug.</p>
4.3.1.7	Ice-trap No gas drying device shall be used before the analysis unless it is shown that it has no effect on the pollutant content of the gas stream.
4.3.2	Particular requirements for compression ignition engines :
4.3.2.1	A heated sample line for a continuous HC-analysis with the heated flame ionisation detector (HFID), including recorder (R) is to be used.
4.3.2.2	The average concentration of the measured hydrocarbons shall be determined by integration. Throughout the test, the temperature of the heated sample line shall be controlled at 463 K (190°C) $\pm 10$ K. The heated sampling line shall be fitted with a heated filter (Fh) 99% efficient with particle $\geq 0.3 \mu\text{m}$ to extract any solid particles from the continuous flow of gas required for analysis.
4.3.2.3	The sampling system response time (from the probe to the analyser inlet) shall be no more than 4s.
4.3.2.3.1	The HFID must be used with a constant flow (heat exchanger) system to ensure a representative sample, unless compensation for varying CFV or CFO flow is made.
4.3.2.4	The particulate sampling unit consist of a dilution tunnel, a sampling probe, a filter unit, a partial flow pump, and a flow rate regulator and measuring unit. The particulate sampling part flow is drawn through two series mounted filters. The sampling probe for the test gas flow for particulates shall be so arranged within the dilution tract that a representative sample gas flow can be taken from the homogenous air /

	<p>exhaust mixture and an air / exhaust gas mixture temperature of 325 K (52°C) shall not exceed immediately before the particulate filter. The temperature of the gas flow in the flow meter shall not fluctuate more than <math>\pm 3K</math>, nor the mass flow rate shall fluctuate more than <math>\pm 5\%</math>. If the volume of flow change unexpectedly as a result of excessive filter loading, the test should be stopped. When it is repeated, the rate of flow shall be decreased and / or larger filter shall be used. The filters shall be removed from the chamber not earlier than an hour before the test begins.</p>
4.3.2.5	<p>The necessary particulate filters should be conditioned (as regards temperature and humidity) in an open dish which shall be protected against dust ingress for at least 8 and not more than 56 hours before the test in an air conditioned chamber After this conditioning, the uncontaminated filters shall be read and stored until they are used.</p> <p>The temperature of the chamber (or room) in which particulate filters are conditioned and weighted shall be maintained to within <math>295 \pm 3^{\circ}K(22^{\circ}C \pm 3^{\circ}C)</math> during all filter conditioning and weighing. The humidity shall be maintained to a dew point of <math>282-3^{\circ}K \pm 3^{\circ}K (9.5^{\circ}C \pm 3^{\circ}C)</math> and a relative humidity of <math>45\% \pm 8\%</math>.</p>
4.3.2.6	<p>If the filters are not used within 1 hour of their removal from the weighing chamber then they shall be re-weighed. The one hour limit shall be replaced by an eight hour limit if one or both of the following conditions are met:</p> <p>A stabilized filter is placed and kept in a sealed filter holder assembly with the ends plugged, or</p> <p>A stabilized filter is placed in a sealed filter holder assembly, which is then Immediately placed in a sample line through which there is no flow.</p>
4.3.3	<b>Calibration :</b>
4.3.3.1	Each analyzer shall be calibrated as often as necessary and in any case in the month before type approval testing and at least once every six months for Verifying conformity of production.
4.3.3.2	The calibration method that shall be used is described in Chapter 7 of this part for the analyzers indicated in para 4.3.1 above.
4.4	<b>Volume measurement :</b>
4.4.1	The method of measuring total dilute exhaust volume incorporated in the constant Volume sampler shall be such that measurement is accurate to within $\pm 2$ per cent.
4.4.2	<b>Constant Volume Sampler Calibration :</b>
4.4.2.1	The Constant Volume Sampler system volume measurement device shall be Calibrated by a suitable method to ensure the prescribed accuracy and at a Frequency sufficient to maintain such accuracy.
4.4.2.2	An example of a calibration procedure which will give the required accuracy is given in Chapter 7 of this part. The method shall utilize a flow-metering device Which is dynamic and suitable for the high flow rate encountered in Constant Volume Sampler testing. The devices shall be

	of certified accuracy traceable to an approved national or international standard.
4.5	<b>Gases :</b>
4.5.1	<p><b>Pure Gases :</b> The following pure gases shall be available when necessary, for calibration and operation:</p> <ul style="list-style-type: none"> <li>• Purified nitrogen (purity <math>\leq</math> 1 ppm C, <math>\leq</math> 1ppm CO, <math>\leq</math> 400 ppm CO<sub>2</sub>, <math>\leq</math> 0.1 ppm NO);</li> <li>• Purified synthetic air (purity <math>\leq</math> 1 ppm C, <math>\leq</math> 1ppm CO, <math>\leq</math> 400 ppm CO<sub>2</sub>, <math>\leq</math> 0.1 ppm NO); oxygen content between 18% &amp; 21% vol.;</li> <li>• Purified oxygen (purity <math>\leq</math> 99.5 per cent Vol O<sub>2</sub>);</li> <li>• Purified hydrogen (and mixture containing hydrogen) (Purity <math>\leq</math> 1ppm C, <math>\leq</math> 400 ppm CO<sub>2</sub>).</li> </ul>
4.5.2	<b>Calibration and span gases :</b>
4.5.3	<p>Gases having the following chemical compositions shall be available of:</p> <ul style="list-style-type: none"> <li>-C<sub>3</sub> H<sub>8</sub> and purified synthetic air, as in para 4.5.1 above</li> <li>-CO and purified nitrogen, as in para 4.5.1 above</li> <li>-CO<sub>2</sub> and purified nitrogen, as in para 4.5.1 above</li> <li>-NO and purified nitrogen, as in para 4.5.1 above (The amount of NO<sub>2</sub> contained in this calibration gas must not exceed 5 percent of the NO content)</li> </ul>
4.5.4	The true concentration of a calibration gas shall be within $\pm$ 2% of the stated figure
	The concentrations specified in Chapter 7 of this part may also be obtained by means of a gas divider, diluting with purified nitrogen or with purified synthetic air. The accuracy of the mixing device shall be such that the concentrations of the diluted calibration gases may be determined within $\pm$ 2%.
4.6	<b>Additional equipment :</b>
4.6.1	Temperatures : The temperature indicated in Chapter 8 of this part shall be measured with an accuracy of $\pm$ 1.5 K.
4.6.2	Pressure : The atmospheric pressure shall be measurable to within $\pm$ 0.1 kPa.
4.6.3	Absolute Humidity : The absolute humidity (H) shall be measurable to within $\pm$ 5 %.
4.7	The exhaust gas-sampling system shall be verified by the method described in para 3 of Chapter 7 of this part. The maximum permissible deviation between the quantity of gas introduced and the quantity of gas measured shall be 5 %.
5	<b>Preparations for the test :</b>
5.1	Adjustment of inertia simulators to the vehicle's translatory inertias: An inertia simulator shall be used enabling a total inertia of the rotating masses to be obtained proportional to the reference weight within the following limits given in Table III.
5.2	<b>Setting of dynamometer :</b>
5.2.1	The load shall be adjusted according to methods described in paragraph 4.1.7 above.

5.2.2

The method used and the values obtained (equivalent inertia, characteristic adjustment parameter) shall be recorded in the test report.

**TABLE I-(A)**  
**OPERATING CYCLE ON THE CHASSIS DYNAMOMETER**  
**(Ref. Para. 2.1.1)**

ECE R40 cycle modified for the maximum speed on the cycle to 43 km/h, as described below

No. of operation	Operation	Phase	Acceleration (m/s <sup>2</sup> )	Speed (km/h)	Duration of each		Cumulative Time (s)	Gear to be used in the case of a manual-shift gearbox
					Operation (s)	Phase (s)		
1	Idling	1	0	0	11	11	11	6 s PM + 5 s K (*)
2	Acceleration	2	1.04	0-15	4	4	15	According to manufacturer's instructions
3	Steady Speed	3	0	15	8	8	23	
4	Deceleration	4	-0.69	15-10	2	5	25	
5	Deceleration, Clutch disengaged		-0.92	10-0	3		28	K (*)
6	Idling	5	0	0	21	21	49	16 s PM + 5 s K (*)
7	Acceleration	6	0.83	0-15	5	12	54	According to manufacturer's instructions
8	Gear Change			15	2		56	
9	Acceleration		0.94	15-32	5		61	
10	Steady Speed	7	0	32	24	24	85	
11	Deceleration	8	-0.75	32-10	8	11	93	

	12	Deceleration, Clutch disengaged		-0.92	10-0	3		96	K (*)
	13	Idling	9	0	0	21	26	117	16 s PM + 5 s K (*)
	14	Acceleration	10	0.83	0-15	5		122	According to manufacturer's instructions
	15	Gear change			15	2		124	
	16	Acceleration		0.62	15-35	9		133	
	17	Gear Change			35	2		135	
	18	Acceleration		0.55	35-43	4		139	
	19	Steady Speed	11	0	43	20	20	159	
	20	Deceleration	12	-0.55	43-35	4	4	163	
	21	Steady Speed	13	0	35	13	13	176	
	22	Gear Change	14		35	2		178	
	23	Deceleration		-0.99	35-10	7		185	
	24	Deceleration, Clutch disengaged		-0.92	10-0	3	12	188	K (*)
	25	Idling	15	0	0	7	7	195	7 s PM (*)
(*) PM = gears in neutral, clutch engaged. K = clutch disengaged.									

**Fig 1 (A):  
SPEED AND TIME TOLERANCES**

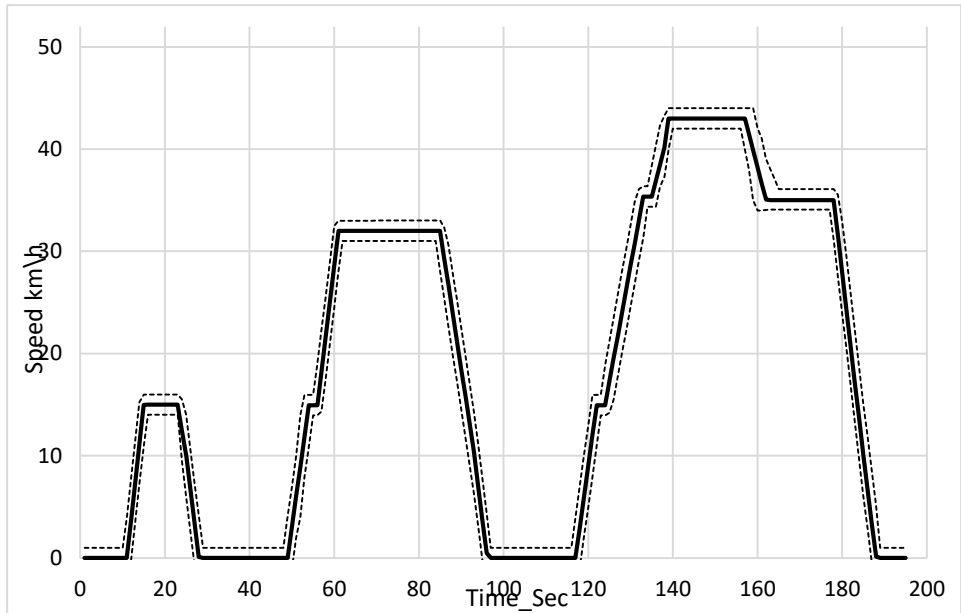

**TABLE I-(B)  
OPERATING CYCLE ON THE CHASSIS DYNAMOMETER  
(Ref. Para. 2.1.1 )**

**Table III  
Classification of equivalent inertia mass and running resistance  
used for L7- quadricycle category vehicles**

Reference mass m ref (kg)	Equivalent inertia mass m i (kg)	Rolling resistance of front wheel a (N)	Aero drag coefficient b (N/(km/h))
205 < m ref ≤ 215	210	18.5	0.0232
215 < m ref ≤ 225	220	19.4	0,0233
225 < m ref ≤ 235	230	20.2	0.0235
235 < m ref ≤ 245	240	21.1	0.0236
245 < m ref ≤ 255	250	22.0	0.0238
255 < m ref ≤ 265	260	22.9	0.0239
265 < m ref ≤ 275	270	23.8	0.0241
275 < m ref ≤ 285	280	24.6	0.0242

285 < m ref ≤ 295	290	25.5	0.0244
295 < m ref ≤ 305	300	26.4	0.0245
305 < m ref ≤ 315	310	27.3	0.0247
315 < m ref ≤ 325	320	28.2	0.0248
325 < m ref ≤ 335	330	29.0	0.0250
335 < m ref ≤ 345	340	29.9	0.0251
345 < m ref ≤ 355	350	30.8	0.0253
355 < m ref ≤ 365	360	31.7	0.0254
365 < m ref ≤ 375	370	32.6	0.0256
375 < m ref ≤ 385	380	33.4	0.0257
385 < m ref ≤ 395	390	34.3	0.0259
395 < m ref ≤ 405	400	35.2	0.0260
405 < m ref ≤ 415	410	36.1	0.0262
415 < m ref ≤ 425	420	37.0	0.0263
425 < m ref ≤ 435	430	37.8	0.0265
435 < m ref ≤ 445	440	38.7	0.0266
445 < m ref ≤ 455	450	39.6	0.0268
455 < m ref ≤ 465	460	40.5	0.0269
465 < m ref ≤ 475	470	41.4	0.0271
475 < m ref ≤ 485	480	42.2	0,0272
485 < m ref ≤ 495	490	43.1	0,0274
495 < m ref ≤ 505	500	44.0	0.0275
At every 10 kg	At every 10 kg	a = 0,088 × m i (*)	b = 0,000015 × m i + 0,02 (**)



5.3	<b>Preconditioning of the vehicle :</b>
5.3.1	For the compression ignition engine vehicles for the purpose of measuring particulates at most 36 hours and at least 6 hours before testing, Table 1 shall be used 6 consecutive cycles shall be driven. The dynamometer setting shall be as per 5.1 and 5.2 above
5.3.2	After this preconditioning specific for compression ignition engines and before testing, compression ignition and positive ignition engine vehicles shall be kept in a room in which a temperature remains relatively constant between 293 K and 303 K (20 and 30°C). The vehicle soaking shall be carried out for at least 6 hours and continue until the engine oil temperature, or coolant temp, or in case or in case of air cooled engines spark plug/gasket temp, equal to the +/- 2K of the air temp, of soak area room.
5.3.3	Soaking period will be from 6 to 36 hours.
5.3.4	The tyre pressure shall be the same as that indicated by the manufacturer and used for the preliminary road test for data collection for adjustment of chassis Dynamometer. The tyre pressure may be increased by up to 50 per cent from the manufacturer's recommended setting in the case of a two roll dynamometer. The actual pressure used shall be recorded in the test report.
6	<b>Procedure for Chassis Dynamometer Test :</b>
6.1	Special conditions for carrying out the cycle :
6.1.1	During the test, the test cell temperature shall be between 293 K and 303 K (20 and 30°C). The absolute humidity (H) of either the air in the test cell or the intake air of the engine shall be such that: $5.5 \leq H \leq 12.2$ gH <sub>2</sub> O/kg dry air
6.1.2	During the test, the speed can be recorded against time so that the correctness of the cycle performed can be assessed.
6.1.3	<b>Cooling of the Vehicle :</b>
6.1.3.1	The blower speed shall be such that, within the operating range of 10 km/h to at least up to 50 km/h the linear velocity of the air at the blower outlet is within $\pm 5$ km/h of the corresponding roller speed. At roller speeds of less than 10 km/h, air velocity may be zero, the blower outlet shall have a cross section area of at least 0.4 m <sup>2</sup> and the bottom of the blower outlet shall be between 15 and 20 cm above floor level. The distance from front end of the vehicle is approx. 30 cm to 45 cm.
6.1.3.2	The device used to measure the linear velocity of the air shall be located in the middle of the stream at 20 cm away from the air outlet. The air velocity shall be 25 km/h $\pm$ 5 km/h. This velocity shall be as nearly constant as possible across the whole of the blower outlet surface. At the request of the manufacturer for special vehicles (e.g Van, Off road) the height of the cooling fan can be modified.
6.2	<b>Starting up the engine :</b>
6.2.1	The engine shall be started up by means of the devices provided for this purpose according to the manufacturer's instructions, as incorporated in the driver's handbook of production vehicles.

6.2.2	The cold start procedure with sampling at T=0 sec i.e. immediately after cranking with initiation of the test cycle to be followed
6.2.2.1	If during the start, the vehicle does not start after 10 seconds of cranking, or ten operations of manual starting mechanism, cranking shall cease and the reason for failure to start shall be determined.
6.2.2.2	The corrective action for this, including those caused by the vehicle malfunction, if it is of less than 30 minutes duration, may be taken and test continued. If the failure to start is caused by vehicle malfunction and the vehicle can not be started, the test shall be cancelled, the vehicle removed from the dynamometer, corrective action taken and the vehicle rescheduled for test (Refer para 5.3.3 above). The reason for malfunction (if determined) and the corrective action taken shall be reported.
6.2.2.3	If the engine stalls during some operating mode other than idle the driving schedule indicator and gas sampling shall be stopped, the vehicle shall then be restarted and accelerated to the speed required at the point in driving schedule and the test and the gas sampling continued. During the acceleration upto this point, gear shifting shall be performed as per para 2.3 of this chapter.
6.2.2.4	If the vehicle does not restart within one minute, the test shall be canceled, the vehicle removed from the dynamometer, corrective action taken, and the vehicle rescheduled for test (refer para 5.3.3 above).
6.2.2.5	The reason for the malfunction (if determined) and the corrective action taken shall be indicated in the test report.
6.2.2.6	During corrective action referred to the paragraphs 6.2.2.2 & 6.2.2.6 above, adjustments and setting only within the limits specified by the manufacturer shall be permitted. Changes outside the limits specified shall be governed by the applicable procedure given in Part VI.
6.3	<b>Idling :</b>
6.3.1	Manual-shift or semi-automatic gear-box :
6.3.1.1	During periods of idling, the clutch shall be engaged and gears in neutral.
6.3.1.2	To enable the accelerations to be performed according to normal cycle the vehicle shall be placed in first gear, with clutch disengaged, 5 seconds before the Acceleration following the idling period considered of the test cycle.
6.3.1.3	The first idling period at the beginning of the cycle shall consist of 11 seconds of idling in neutral with the clutch engaged and 5 seconds in first gear with the clutch disengaged.
6.3.2	Automatic-shift gear-box: After initial engagement, the selector shall not be operated at any time during the test except in accordance with paragraph 6.4.3 below.
6.4	<b>Accelerations:</b>
6.4.1	Accelerations shall be so performed that the rate of acceleration shall be as constant as possible throughout the phase.

6.4.2	If an acceleration cannot be carried out in the prescribed time, the extra time required is, if possible, deducted from the time allowed for changing gear, but otherwise from the subsequent steady speed period.
6.4.3	Automatic-shift gear-boxes : If an acceleration cannot be carried out in the prescribed time the gear selector shall be operated in accordance with requirements for manual-shift gear-boxes.
6.5	<b>Decelerations :</b>
6.5.1	If the period of deceleration is longer than that prescribed for the corresponding phase, the vehicle's brakes shall be used to enable the timing of the cycle to be abided by.
6.5.2	If the period of deceleration is shorter than that prescribed for the corresponding phase, the timing of theoretical cycle shall be restored by constant speed or idling period merging into the following operation
6.6	<b>Steady Speeds :</b>
6.6.1	"Pumping" or the closing of the throttle shall be avoided when passing from acceleration to the following steady speed.
6.6.2	Periods of constant speed shall be achieved by keeping the accelerator position fixed.
7	<b>Procedure for Sampling and Analysis :</b>
7.1	<b>Sampling :</b>
7.1.1	Sampling for all vehicles shall begin at the T=0 and shall complete at the end of the sixth cycle
7.2	<b>Analysis :</b>
7.2.1	The exhaust gases contained in the bag shall be analysed as soon as possible and in any event not later than 20 minutes after the end of the test cycle. The spent particulate filters must be taken to the chamber no later than 1 hour after conclusion of the test on the exhaust gases and must be conditioned for between 2 & 36 hours and then be weighed.
7.2.2	Prior to each sample analysis the analyser range to be used for each pollutant shall be set to zero with the appropriate zero gas.
7.2.3	The analysers shall then be set to the calibration curves by means of span gases of nominal concentrations of 70 to 100 percent of the range
7.2.4	The analysers' zeros shall then be re-checked. If the reading differs by more than 2 percent of range from that set in paragraph 7.2.2 above, the procedure shall be repeated.
7.2.5	The samples shall then be analysed.
7.2.6	After the analysis zero and span points shall be re-checked using the same gases. If these re-checks are within 2 percent of those in paragraph 7.2.3, then the analysis shall be considered acceptable.
7.2.7	For all the points in this section, the flow rates and pressure of the various gases must be the same as those used during calibration of the analysers.
7.2.8	The figure adopted for the content of the gases in each of the pollutants measured shall be that read off after stabilisation of the measuring device. Diesel hydrocarbon mass emissions shall be calculated from the

	integrated HFID reading corrected for varying flow, if necessary as shown in Chapter 6 of this part.
<b>8</b>	<b>Determination of the Quantity of Gaseous Pollutants Emitted :</b>
8.1	The volume considered : The volume to be considered shall be corrected to conform to the conditions of 101.3 kPa and 293 K.
8.2	<p>Total Mass of Gaseous Pollutants Emitted : The mass, M, of each pollutant emitted by the vehicle during the test shall be determined by obtaining the product of the voluminal concentration and the volume of the gas in question, with due regard for the following densities at the above mentioned reference condition.</p> <p>- in the case of carbon monoxide (CO): <math>d = 1.164 \text{ kg/m}^3</math>  in the case of hydrocarbons (<math>\text{CH}_{1.85}</math>):  for petrol (<math>\text{CH}_{1.85}</math>) <math>d = 0.5768 \text{ Kg/ m}^3</math>  for diesel (<math>\text{CH}_{1.86}</math>) <math>d = 0.5768 \text{ Kg/ m}^3</math>  for LPG (<math>\text{CH}_{2.525}</math>) <math>d = 0.6047 \text{ Kg/ m}^3</math>  for CNG (<math>\text{CH}_4</math>) <math>d = 0.665 \text{ Kg/ m}^3</math>  in the case of nitrogen oxides (<math>\text{NO}_x</math>): <math>d = 1.913 \text{ kg/ m}^3</math>.  in the case of Carbon Dioxides (<math>\text{CO}_2</math>): <math>d = 1.830 \text{ kg/ m}^3</math>.</p> <p>The mass 'm' of particulate pollutant emissions from the vehicle during the test is defined by weighing the mass of particulates collected by two filters, 'm1' by the first filter, 'm2' by the second filter.</p> <p>- if <math>0.95 (m1 + m2) \leq m1</math>, <math>m = m1</math>,  - if <math>0.95 (m1 + m2) &gt; m1</math>, <math>m = m1 + m2</math>,  - if <math>m2 &gt; m1</math>, the test shall be cancelled.</p>
8.3	Chapter 8 of this Part describes the calculations, followed by examples, used in determining the mass emissions of gaseous and particulates.

## Chapter 4

### **RESISTANCE TO PROGRESS OF A VEHICLE - MEASUREMENT METHOD ON THE ROAD - SIMULATION ON A CHASSIS DYNAMOMETER**

1	<b>Scope :</b>
	This Chapter describes the methods to measure the resistance to the progress of a vehicle at stabilised speeds on the road and to simulate this resistance on a chassis dynamometer with adjustable load curves in accordance with paragraph 4.1.7.1 of Chapter 3 of this part.
2	<b>Definition of the road :</b>
2.1	The road shall be level and sufficiently long to enable the measurements specified below to be made. The longitudinal slope shall not exceed 1.5% and shall be constant within $\pm 0.1$ % over the measuring strip.
3	<b>Atmospheric Conditions :</b>
3.1	Wind : Testing must be limited to wind speeds averaging less than 3 m/s with peak speeds less than 5 m/s. In addition, the vector component of the wind speed across the test road must be less than 2 m/s. Wind velocity should be measured 0.7 m above the road surface.
3.2	<b>Humidity :</b> The road shall be dry.
3.3	<b>Pressure - Temperature :</b> Air density at the time of the test shall not deviate by more than $\pm 7.5$ percent from the reference conditions: $P = 100$ kPa & $T = 293.2$ K
4	<b>Vehicle Preparation :</b>
4.1	<b>Running in :</b> The vehicle shall be in normal running order and adjusted after having been run-in as per manufacturer's specifications. The tyres shall be run in at the same time as the vehicle or shall have a tread depth within 90 and 50 percent of the initial tread depth.
4.2	<b>Verifications :</b> The following verifications shall be made in accordance with the manufacturer's specifications for the use considered : -wheel, wheel trims, tyres (make, type, pressure), -front axle geometry, -brake adjustment (elimination of parasitic drag) -lubrication of front and rear axles, -adjustment of the suspension and vehicle level, etc.
4.3	<b>Preparation for the test:</b> The vehicle shall be loaded to its reference mass. The level of the vehicle shall be that obtained when the centre of gravity of the load is situated midway between the "R" points of the front outer seats and on a straight line passing through those points.
4.3.1	In case of road tests, the windows of the vehicle shall be closed. Any covers of air climatization systems, headlamps, etc., shall be in the non-operating position.
4.3.2	The vehicle shall be clean.
4.3.3	Immediately prior to the test the vehicle shall be brought to normal running temperature in an appropriate manner.
5	Methods for chassis dynamometer with adjustable load curve

5.1	Energy variation during coast-down method:																																							
5.1.1	On the road																																							
5.1.1.1	Accuracies of test equipment Time shall be measured accurate to within 0.1 second. Speed shall be measured accurate to within 2 percent.																																							
5.1.1.2	Test procedure																																							
5.1.1.2.1	Accelerate the vehicle to a speed of 10 km/h greater than the chosen test speed, V.																																							
5.1.1.2.2	Place the gear box in "neutral" position.																																							
5.1.1.3	Measure the time taken (t1) for the vehicle to decelerate from $V_2 = V + \Delta V$ km/h to $V_1 = V - \Delta V$ km/h : with with $V \leq 5$ km/h																																							
5.1.1.4	Perform the same test in the opposite direction: t <sub>2</sub>																																							
5.1.1.5	Take the average T, of the two times t <sub>1</sub> and t <sub>2</sub>																																							
5.1.1.6	<b>Repeat these tests several times such that the statistical accuracy (p) of the average</b>																																							
	$T = \frac{1}{n} \sum_{i=1}^n t_i$ is not more than 2% ( $p \leq 2\%$ )																																							
	<p>The statistical accuracy (p) is defined by :</p> $p = \frac{t * s}{\sqrt{n}} * \frac{100}{T}$ <p>where, t = coefficient given by the table below</p> <p>s = standard deviation = <math>\sqrt{\frac{\sum (T_i - T)^2}{(n-1)}}</math></p> <p>n = number of tests</p> <table border="1"> <tr> <td>N</td> <td>4</td> <td>5</td> <td>6</td> <td>7</td> <td>8</td> <td>9</td> <td>10</td> <td>11</td> <td>12</td> <td>13</td> <td>14</td> <td>15</td> </tr> <tr> <td>T</td> <td>3.2</td> <td>2.8</td> <td>2.6</td> <td>2.5</td> <td>2.4</td> <td>2.3</td> <td>2.2</td> <td>2.2</td> <td>2.2</td> <td>2.2</td> <td>2.2</td> <td>2.2</td> </tr> <tr> <td><math>\frac{t}{\sqrt{n}}</math></td> <td>1.6</td> <td>1.25</td> <td>1.06</td> <td>0.94</td> <td>0.85</td> <td>0.77</td> <td>0.73</td> <td>0.66</td> <td>0.64</td> <td>0.61</td> <td>0.5</td> <td>0.57</td> </tr> </table>	N	4	5	6	7	8	9	10	11	12	13	14	15	T	3.2	2.8	2.6	2.5	2.4	2.3	2.2	2.2	2.2	2.2	2.2	2.2	$\frac{t}{\sqrt{n}}$	1.6	1.25	1.06	0.94	0.85	0.77	0.73	0.66	0.64	0.61	0.5	0.57
N	4	5	6	7	8	9	10	11	12	13	14	15																												
T	3.2	2.8	2.6	2.5	2.4	2.3	2.2	2.2	2.2	2.2	2.2	2.2																												
$\frac{t}{\sqrt{n}}$	1.6	1.25	1.06	0.94	0.85	0.77	0.73	0.66	0.64	0.61	0.5	0.57																												
5.1.1.7	<p>Calculate the power by the formula :</p> $P = \frac{m * V * \Delta V}{500 * T}$ <p>where,</p> <p><i>P</i> is expressed in kW  <i>V</i> = speed of the test in m/s  <math>\Delta V</math> = speed deviation from speed V, in m/s  <i>m</i> = reference mass in kg  <i>T</i> = time in seconds</p>																																							

	Alternatively, the coast down shall be carried out as per IS 14785-1999 to establish “a” and “b” coefficients for setting on chassis dynamometer.												
5.1.1.8	<p>The power (P) determined on the track shall be corrected to the reference ambient conditions as follows:  P corrected = K * P measured</p> $K = \frac{R_R}{R_T} \left[ 1 + K_R (t - t_0) \right] + \frac{R_{AERO}}{R_T} \cdot \frac{(\rho_0)}{\rho}$ <p>Where  R<sub>R</sub> = rolling resistance at speed V  R<sub>AERO</sub> = aerodynamic drag at speed V  R<sub>T</sub> = total driving resistance = R<sub>R</sub> + R<sub>AERO</sub>  K<sub>R</sub> = temperature correction factor of rolling resistance, taken to be equal to: 8.64 x 10<sup>-3</sup> / degrees C or the manufacturer’s correction factor that is approved by the authority.  t = road test ambient temperature in degrees C  t<sub>0</sub> = reference ambient temperature = 20 degrees C  ρ = air density at the test conditions  ρ<sub>0</sub> = air density at the reference conditions (20 degrees C, 100 kPa)</p> <p>The ratios R<sub>R</sub> / R<sub>T</sub> and R<sub>AERO</sub>/ R<sub>T</sub> shall be specified by the vehicle manufacturer on the basis of the data normally available to the company. If these values are not available, subject to the agreement of the manufacturer and the technical service concerned, the figures for the rolling/ total resistance ratio given by the following formula may be used:</p> $\frac{R_R}{R_T} = a * M + b$ <p>Where:  M= vehicle mass in kg  And for each speed the coefficients a and b are shown in the following table:</p> <table border="1" style="margin-left: auto; margin-right: auto;"> <thead> <tr> <th>V (km /h)</th> <th>a</th> <th>b</th> </tr> </thead> <tbody> <tr> <td>20</td> <td>7.24 x 10<sup>-5</sup></td> <td>0.82</td> </tr> <tr> <td>40</td> <td>1.59 x 10<sup>-4</sup></td> <td>0.54</td> </tr> <tr> <td>60</td> <td>1.96 x 10<sup>-4</sup></td> <td>0.33</td> </tr> </tbody> </table>	V (km /h)	a	b	20	7.24 x 10 <sup>-5</sup>	0.82	40	1.59 x 10 <sup>-4</sup>	0.54	60	1.96 x 10 <sup>-4</sup>	0.33
V (km /h)	a	b											
20	7.24 x 10 <sup>-5</sup>	0.82											
40	1.59 x 10 <sup>-4</sup>	0.54											
60	1.96 x 10 <sup>-4</sup>	0.33											
5.1.2	On the chassis dynamometer :												
5.1.2.1	Measurement equipment and accuracy : The equipment shall be identical to that used on the road.												
5.1.2.2	Test procedure :												
5.1.2.2.1	Install the vehicle on the test dynamometer.												
5.1.2.2.2	Adjust the tyre pressure (cold) of the driving wheels as required by the chassis dynamometer.												
5.1.2.2.3	Adjust the equivalent inertia of the chassis dynamometer.												

5.1.2.2.4	Bring the vehicle and chassis dynamometer to operating temperature in a suitable manner.
5.1.2.2.5	Carry out the following operations specified in paragraph 5.1.1.2 with the exception of paragraphs 5.1.1.2.4 and 5.1.1.2.5 and with changing m by l in the formula of paragraph 5.1.1.2.7 above.
5.1.2.2.6	Adjust the chassis dynamometer to meet the requirements of paragraphs of 4.1.6.1 of Chapters of this Part.
5.2	Torque measurements method at constant speed :
5.2.1	On the road :
5.2.1.1	Measurement equipment and error:
	Torque measurement shall be carried out with an appropriate measuring device, accurate to within 2 %. Speed measurement shall be accurate to within 2 %.
5.2.1.2	Test procedure
5.2.1.2.1	Bring the vehicle to the chosen stabilised speed, V.
5.2.1.2.2	Record the torque C(t) and speed over a period t(of at least 10 s) by means of class 1000 instrumentation meeting ISO standard No. 970, over small intervals of time t.
5.2.1.2.3	Differences in torque, and speed relative to time shall not exceed 5% for each second of the measurement period. The torque is the average  $C_{t_1} = \frac{1}{\Delta t} \int_t^{t+\Delta t} C(t) dt$
5.2.1.2.4	Carry out the test in the opposite direction and find out the average torque i.e. Ct.
5.2.1.2.5	Determine the average of these torques Ct and Ct2 i.e.Ct
5.2.2.	On the chassis dynamometer
5.2.2.1	Measurement equipment and errorThe equipment shall be identical to that used on the road.
5.2.2.2	Test procedure
5.2.2.2.1	Perform the operations specified in paragraphs 5.1 .2.2.1 to 5.1 .2.2.4 above.
5.2.2.2.2	Adjust the chassis dynamometer setting to meet the requirements of paragraph 4.1 .6.1 .of Chapter 3 of this Part.
5.3	Integrated torque over vehicle driving pattern :
5.3.1	This method is a non-obligatory complement to the constant speed method described in paragraph 5.2 above.
5.3.2	Inthis dynamic procedure the mean torque value M is determined. This is accomplished by integrating the actual torque values, M(t) , with respect to time during operation of the test vehicle with a defined driving cycle. The integrated torque is then divided by the time difference t <sub>2</sub> - t <sub>1</sub> ,  The result is :



	$\bar{M} = \frac{1}{t_2 - t_1} \int_{t_1}^{t_2} M(t) * dt \text{ (with } M(t) > 0)$ <p>M is calculated from six sets of results.</p> <p>It is recommended that the sampling rate of <math>\bar{M}</math> be not less than two samples per second.</p>
5.3.3	<p>Dynamometer setting : The dynamometer load is set by the method described in paragraph 5.2 above. If M (dynamometer) does not match M (road) then the inertia setting shall be adjusted until the values are equal within <math>\pm 5</math> percent.</p> <p>Note: The method can only be used for dynamometers with electrical inertia simulation or fine adjustment.</p>
5.3.3.1	Acceptance criteria: Standard deviation of six measurements must be less than or equal to 2 % of the mean value.
5.4	Method by deceleration measurement by gyroscopic platform :
5.4.1	On the road :
5.4.1.1	<p>Measurement equipment and accuracy :</p> <ul style="list-style-type: none"> <li>• Speed shall be measured with an accuracy better than 2 %.</li> <li>• Deceleration shall be measured with an accuracy better than 1 %.</li> <li>• The slope of the road shall be measured with an accuracy better than 1%.</li> <li>• Time shall be measured with an accuracy better than 0.1 s.</li> <li>• The level of the vehicle is measured on a reference horizontal ground: as an alternative, it is possible to correct for the slope of the road ( a1).</li> </ul>
5.4.1.2	Test procedure :
5.4.1.2.1	Accelerate the vehicle to a speed 5 km/h greater than the chosen test speed V.
5.4.1.2.2	Record the deceleration between V + 0.5 km/h and V - 0.5 km/h.
5.4.1.2.3	<p>Calculate the average deceleration attributed to the speed V by the formula:</p> $\bar{\gamma}_1 = \frac{1}{t} \int_0^t \gamma_1(t) dt - (g \cdot \sin \alpha_1)$ <p>where:</p> <p><math>\bar{\gamma}_1</math> = average deceleration value at the speed V in one direction of the road</p> <p>t = time between V + 0.5 km/h and V - 0.5 km/h</p> <p><math>\gamma_1(t)</math> = deceleration recorded with the time</p> <p>g = 9.81 m/s<sup>2</sup>.</p>
5.4.1.2.4	Perform the same test in the other direction -y2
5.4.1.2.5	Calculate the average deceleration i.e.

	$\gamma_i = \frac{\gamma_1 + \gamma_2}{2}$ for test I.
5.4.1.1.1	Perform a sufficient number of tests as specified in paragraph 5.1.1.2.6 above replacing T by y where
5.4.1.1.1	Calculate the average force absorbed $F = m \cdot y$ , where m = vehicle reference mass in kg & y = average deceleration calculated as above.
5.4.2	On the chassis dynamometer :
5.4.2.1	Measuring equipment and accuracy The measurement instrumentation of the chassis dynamometer itself shall be used as defined in para 5.1.2.1 of this Part.
5.4.2.2	<p>Test procedure Adjustment of the force on the rim under steady speed. On chassis dynamometer, the total resistance is of the type:</p> $F_{\text{total}} = F_{\text{indicated}} + F_{\text{driving axle rolling}}$ <p>with</p> $F_{\text{total}} = F_{\text{road}}$ $F_{\text{indicated}} = F_{\text{road}} - F_{\text{driving axle rolling}}$ <p>where : F indicated is the force indicated on the force indicating device of the chassis dynamometer. F(road) is known.</p> <p>33F driving axle rolling , can be measured on chassis dynamometer driving axle rolling able to work as generator. The test vehicle, gear box in neutral position, is driven by the dynamometer at the test speed; the rolling resistance, RR, of the driving axle is then measured on the force indicating device of the chassis dynamometer.</p> <p>Determination on chassis dynamometer unable to work as a generator. For the two-roller chassis dynamometer, the RR value is the one which is determined before on the road.</p> <p>For the single-roller chassis dynamometer, the RR value is the one which is determined on the road multiplied by a coefficient R which is equal to the ratio between the driving axle mass and the vehicle total mass. Note : RR is obtained from the curve <math>F = f(V)</math>.</p>
5.4.2.2.1	Calibrate the force indicator for the chosen speed of the roller bench as defined in para 2 Chapter 5 of this Part.
5.4.1.3.6	perform the same operation as in paragraphs 5.1.2.2.1 to 5.1.2.2.4 above.
5.4.1.3.7	Set the force, $F_A = F - F_R$ on the indicator for the speed chosen.
5.4.2.2.4	Carry out a sufficient number of tests as indicated in paragraph 5.1.1.2.6 above, replacing T by $F_A$ .
5.5	Deceleration Method applying coast-down techniques :
5.5.1	On the Road
5.5.1.1	Accuracies of the test instrument shall be the same as specified in 5.1.1.1.
5.5.1.2	Drive the vehicle at a constant speed of about 10 km/h more than the chosen test speed, $V_{\text{km/h}}$ , along a straight line.

5.5.1.3	After this speed is held steady for a distance of at-least 100 m, disconnect the engine from the drive line by bringing the gear to neutral or by other means in the case of vehicle where manual shifting to neutral is not possible.
5.5.1.4	Measure the time taken (11 sec) for the speed to drop from V + AV km/h to V - AV km/h. The value of AV shall not be less than 1 km/h or more than 5 km/h. However, same value of A V shall be used for all the tests.
5.5.1.5	Repeat the test in the opposite direction and record the time (12 sec.). Repeat the test 10 times such that the statistical error of the time t <sub>i</sub> (arithmetic average of t <sub>1</sub> and t <sub>2</sub> ) is equal to or less than 2%
5.5.1.6	The statistical error 'p' is calculated as - $p = \frac{24.24 * (t_i - t_m)^2}{t_m}$ <p>Where, t = average time for each consecutive set of reading, <math>\frac{t_1 + t_2}{2}</math>  t<sub>m</sub> = Arithmetic average of 10 such t<sub>i</sub></p>
5.5.1.7	The basic equation of motion to calculate the road load resistance force, F, is $F = \frac{(W + W_2) * V}{(3.6 * t_m * g)}$ <p>where,  F - in N  W - the weight of the test vehicle in N  W<sub>2</sub> - equivalent inertia weight of rotating axle(0.035 x mass of the test vehicle for four-wheeled vehicles) in N  V - vehicle speed difference during the coast down, in km/h  t<sub>m</sub> - coast down time, in seconds  g - acceleration due to gravity, 9.81 m/s<sup>2</sup></p>
5.5.1.8	Using least square curve fitting method and values of F and V, the coefficient of rolling and aerodynamic resistance of the vehicle viz. a and b respectively are found from the following equation : F = a + b* V <sup>2</sup>
5.5.2	Chassis Dynamometer Setting : The values of a and b are set on the dynamometer.
5.5.3	In case of vehicle with permanent all wheel drive, the vehicle shall be tested on 4*4 dynamometer preferably

**Chapter 5**  
**VERIFICATION OF INERTIA OTHER THAN MECHANICAL**

1	<b>Scope :</b>
1.1	This Chapter describes the method to check that the simulated total inertia of the dynamometer is carried out satisfactorily in the running phases of the operating cycle.
2	<b>Principle:</b>
2.1	Drawing up working equations:
2.1.1	<p>Since the chassis dynamometer is subjected to variations in the rotating speed of the roller(s), the force at the surface of the roller(s) can be expressed by the formula:</p> $F = I * \gamma = I_M * \gamma + F_I$ <p>Where, F = force at the surface of the roller(s)  I = total inertia of the chassis dynamometer (equivalent inertia of the vehicle as in Table III of Chapter 3 of this Part).  I<sub>M</sub> = inertia of the mechanical masses of the chassis dynamometer  γ = tangential acceleration at roller surface  F<sub>I</sub> = inertia force</p>
2.1.2	<p>The total inertia is expressed as follows :</p> $I = I_M + \frac{F_I}{\gamma}$ <p>where  I<sub>M</sub> can be calculated or measured by traditional methods  F<sub>I</sub> can be measured on the bench  γ can be calculated from the peripheral speed of the rollers</p>
2.1.3	The total inertia "I" will be determined during an acceleration or deceleration test with values higher than or equal to those obtained on an operating cycle.
2.2	Specification for the calculation of total inertia :
	The test and calculation methods must make it possible to determine total inertia I with a relative error ( ΔI / I) of less than 2 %.
3	<b>Specifice:</b>
3.1	The mass of the simulated total inertia I must remain the same as the theoretical value of the equivalent inertia (paragraph 5.1 of Chapter 3 of this Part) within the following limits.
3.1.1	±5 % of the theoretical value for each instantaneous value.
3.1.2	± 2 % of the theoretical value for the average value calculated for each sequence of the cycle.

3.2	The limit given in paragraph 3.1.1 is brought to $\pm 50$ percent for one second when starting and, for vehicles with manual transmission, for two seconds during gear changes.
4	Verification Procedure:
4.1	Verification is carried out during each test throughout the cycle defined in paragraph 2.1 of chapter 3 of this part.
4.2	However, if the provisions of paragraph 3 above are met, with instantaneous accelerations which are at least three times greater or smaller than the values obtained in the sequences of the theoretical cycle, the verification described above will not be necessary.
5	Technical Note : Explanation of drawing up working equations
5.1	Equilibrium of the forces on the road, $CR = k_1 J r_1 \frac{d\theta_1}{dt} + k_2 J r_2 \frac{d\theta_2}{dt} + k_3 M \gamma r_1 + k_3 F_s r_1$
5.2	Equilibrium of the forces on dynamometer with mechanical simulated inertias $C_m = k_1 J r_1 \frac{d\theta_1}{dt} + k_3 \frac{J R_m}{R_m} \frac{dW_m}{dt} r_1 + k_3 F_s r_1$ $= k_1 J r_1 \frac{d\theta_1}{dt} + k_3 I \gamma r_1 + k_3 F_s r_1$
5.3	Equilibrium of the forces of dynamometer with non-mechanically simulated inertias $C_e = k_1 J r_1 \frac{d\theta_1}{dt} + \left( k_3 \frac{J R_e}{R_e} \frac{dW_e}{dt} r_1 + \frac{C_1}{R_e} r_1 \right) + k_3 F_s r_1$ $= k_1 J r_1 \frac{d\theta_1}{dt} + k_3 (I_M \gamma + F_1) r_1 + k_3 F_s r_1$ <p>In these formulae :</p> <p>CR = engine torque on the road</p> <p>C<sub>m</sub>= engine torque on the chassis dynamometer with mechanically simulated inertias</p> <p>C<sub>e</sub> = engine torque on the chassis dynamometer with electrically simulated inertias</p> <p>Jr<sub>1</sub> = Moment of inertia of the vehicle transmission brought back to the driving wheels</p> <p>Jr<sub>2</sub>= Moment of inertia of the non-driving wheels</p>

<p><math>JR_m</math>= Moment of inertia of the bench with mechanically simulated inertias</p> <p><math>JR_e</math>= Moment of mechanical inertia of the chassis dynamometer with electrically simulated inertias</p> <p><math>M</math> = Mass of the vehicle on the road</p> <p><math>I</math> = Equivalent inertia of the chassis dynamometer with electrically simulated inertias</p> <p><math>IM</math>= Mechanical Inertia of the chassis dynamometer with electrically simulated inertia.</p> <p><math>F_s</math>= Resultant force at stabilized speed.</p> <p><math>C_1</math>= Resultant torque from electrically simulated inertias</p> <p><math>F_1</math> = Resultant force from electrically simulated inertias</p> <p><math>\frac{d\theta_1}{dt}</math> = Angular acceleration of the driving wheels</p> <p><math>\frac{d\theta_2}{dt}</math> = Angular acceleration of the non-driving wheels</p> <p><math>\frac{dW_m}{dt}</math> = Angular acceleration of the mechanical chassis dynamometer</p> <p><math>\frac{dW_e}{dt}</math> = Angular acceleration of the electrical chassis dynamometer</p> <p><math>\gamma</math> = Linear acceleration</p> <p><math>r_1</math>= Radius under load of the driving wheels</p> <p><math>r_2</math> = Radius under load of the non-driving wheels</p> <p><math>R_m</math>= Radius of the rollers of the mechanical chassis dynamometer</p> <p><math>R_e</math>= Radius of the rollers of the electrical chassis dynamometer</p> <p><math>k_1</math>= Coefficient dependent on the gear reduction ratio and the various inertias of transmission and "efficiency"</p> <p><math>k_2</math> = Ratio transmission * <math>(r_1/r_2)</math> * "efficiency"</p> <p><math>k_3</math>= Ratio transmission * "efficiency"</p>
---

5.4	Supposing the two types of bench (Paragraphs 5.2 and 5.3 above) are made equal and simplified, one obtains : $k_3 * (I_M * \gamma + F_1) * r_1 = k_3 * I * \gamma * r_1$ where $-I = I_M + (F_1 / \gamma)$
-----	--

**Chapter 6**  
**GAS SAMPLING SYSTEMS**

1	<b>Scope :</b>
1.1	This Chapter describes two types of gas sampling systems in paragraphs 2.1 and 2.2 meeting the requirements specified in para 4.2 of Chapter 3 of this part. Another type described in paragraph 2.3, may be used if it meets these requirements.
1.2	The laboratory shall mention, in its communications, the system of sampling used when performing the test. Systems not described in this chapter could be used, if it is proven to give equivalent results.
2	Criteria relating to the variable-dilution system for measuring exhaust-Gas Emissions
2.1	Scope
	This section-specifies the operating characteristics of an exhaust-gas sampling system intended to be used for measuring the true mass emissions of a vehicle exhaust in accordance with the provisions of this Part. The principle of variable-dilution sampling for measuring mass emissions requires three conditions to be satisfied.
2.1.1	The vehicle exhaust gases must be continuously diluted with ambient air under specified conditions;
2.1.2	The total volume of the exhaust gases and dilution air must be measured accurately;
2.1.3	A continuously proportional sample of the dilution exhaust gases and the dilution air must be collected for analysis,The quantity of gaseous pollutants emitted is determined from the proportional sample concentrations and the total volume measured during the test. The sample concentrations are corrected to take account of the pollutant content of the ambient air. In addition, where vehicles are equipped with compression ignition engines, their particulate emissions are measured.
2.2	Technical summary:
	Figure 3 gives a schematic diagram of the sampling system.
2.2.1	The vehicle exhaust gases must be diluted with a sufficient of ambient air to prevent any water condensation in the sampling and measuring system.
2.2.2	The exhaust-gas sampling system must be so designed as to make it possible to measure the average volume concentrations of the CO <sub>2</sub> , CO, HC and NO <sub>x</sub> , and in addition, in the case of vehicles equipped with compress ion-ignition engines, of the particulate emissions, contained in the exhaust gases emitted during the vehicle testing cycle.
2.2.3	The mixture of air and exhaust gases must be homogeneous at the point where the sampling probe is located (see 2.3.1.2 below).



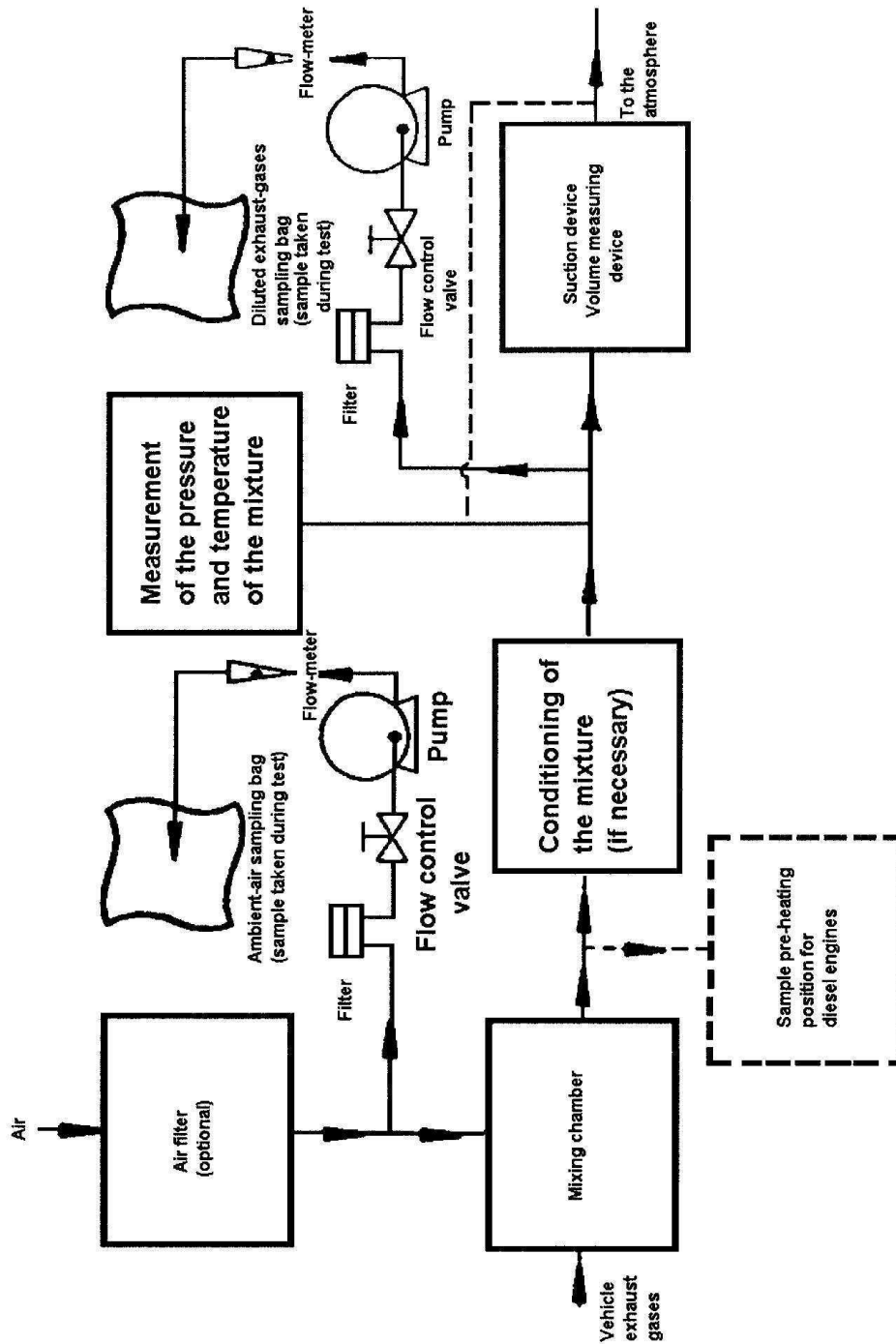

**Fig 3. Diagram of Variable –Dilution System for Measuring Exhaust Gas Emission**

2.2.4	The probe must extract a representative sample of the diluted gases.
2.2.5	The system must make it possible to measure the total volume of the diluted exhaust gases from the vehicle being tested.
2.2.6	The sampling system must be gas-tight. The design of the variable-dilution sampling system and the material that go to make it up must be such that they do not affect the pollutant concentration in the diluted exhaust gases. Should any component in the system (heat exchanger, cyclone separator, blower etc) change the concentration of any of the pollutants in the diluted exhaust gases and the fault cannot be corrected, then sampling for that pollutant must be carried out before that component.
2.2.7	If the vehicle tested is equipped with an exhaust system comprising more than one tailpipe, the connecting tubes must be connected together by a manifold installed as near as possible to the vehicle.
2.2.8	The gas samples must be collected in sampling bags of adequate capacity so as to hinder the gas flow during the sampling period. These bags must be made of such materials as will not affect the concentration of pollutant gases (see 2.3.4.4 below).
2.2.9	The variable-dilution system must be so designed as to enable the exhaust gases to be sampled without appreciably changing the back-pressure at the exhaust pipe outlet (see 2.3.1.1 below).
2.3	Specific requirements
2.3.1	Exhaust-gas collection and dilution device
2.3.1.1	The connection tube between the vehicle exhaust tailpipe(s) and the mixing chamber must be as short as possible; it must in no case: <ul style="list-style-type: none"> <li>- cause the static pressure at the exhaust tailpipe(s) on the vehicle being tested to differ by more than <math>\pm 0.75</math> kPa at 50 km/h or more than <math>\pm 1.25</math> kPa for the whole duration of the test from the static pressures recorded when nothing is connected to the vehicle tailpipes. The pressure must be measured in the exhaust tailpipe or in an extension having the same diameter, as near as possible to the end of the pipe.</li> <li>- Change the nature of the exhaust gas.</li> </ul>
2.3.1.2	There must be a mixing chamber in which the vehicle exhaust gases and the dilution air are mixed so as to produce a homogeneous mixture at the chamber outlet. The homogeneity of the mixture in any cross-section at the location of the sampling probe must not vary by more than $\pm 2$ % from the average of the values obtained at least five points located at equal intervals on the diameter of the gas system. In order to minimize the effects on the conditions at the exhaust tailpipe and to limit the drop in pressure inside the dilution air-conditioning device, if any, the pressure inside the mixing chamber must not differ by more than 0.25 kPa from atmospheric pressure.
2.3.2	Suction device/volume measuring device

	This device may have a range of fixed speeds so as to ensure sufficient flow to prevent any water condensation. This result is generally obtained by keeping the concentration of CO <sub>2</sub> in the dilute exhaust gas sampling bag lower than 3% by volume
2.3.2	Volume measurement:
2.3.2.1	The volume-measuring device must retain its calibration accuracy to within $\pm 2\%$ under all operating conditions. If the device cannot compensate for variations in the temperature of the mixture of exhaust gases and dilution air at the measuring point, a heat exchanger must be used to maintain the temperature to within $\pm 6$ K of the specified operating temperature.  If necessary, a cyclone separator can be used to protect the volume-measuring device.
2.3.2.2	A temperature sensor must be installed immediately before the volume-measuring device. This temperature sensor must have an accuracy and a precision of $\pm 1$ K and a response time of 0.1 second at 62% of a given temperature variation (value measured in silicone oil).
2.3.2.3	The pressure measurements must have a precision and an accuracy of $\pm 0.4$ kPa during the test.
2.3.2.4	The measurement of the pressure difference from atmospheric pressure is taken before and, if necessary, after the volume-measuring device.
2.3.3	Gas sampling:
2.3.3.1	Dilute exhaust gases
2.3.3.1.1	The sample of dilute exhaust gases is taken before the suction devices but after the conditioning devices (if any).
2.3.3.1.2	The flow-rate must not deviate by more than $\pm 2\%$ from the average.
2.3.3.1.3	The sampling rate must not fall below 5 litres per minute and must not exceed 0.2% of the flow-rate of the dilute exhaust gases.
2.3.3.1.4	An equivalent limit applies to constant-mass sampling systems.
2.3.3.2	Dilution air
2.3.3.2.1	A sample of the dilution air is taken at a constant flow-rate near the ambient air inlet (after the filter if one is fitted).
2.3.3.2.2	The air must not be contaminated by exhaust gases from the mixing area.
2.3.3.2.3	The sampling rate for the dilution air must be comparable to that used in the case of the dilute exhaust gases.
2.3.3.3	Sampling operations
2.3.3.3.1	The materials used for the sampling operations must be such that they do not change the pollutant concentration.

2.3.3.3.2	Filters may be used in order to extract the solid particles from the sample.
2.3.3.3.3	Pumps are required in order to convey the sample to the sampling bag(s).
2.3.3.3.4	Flow control valves and flow-meters are needed in order to obtain the flow-rates required for sampling.
2.3.3.3.5	Quick fastening gas-tight connections may be used between the three-way valves and the sampling bags, the connections sealing themselves automatically on the bag side. Other systems may be used for conveying the samples to the analyzer (three-way stop valves, for example).
2.3.3.3.6	The various valves used for directing the sampling gases must be of the quick-adjusting and quick-acting type.
2.3.3.4	Storage of the sample The gas samples are collected in sampling bags of adequate capacity so as not to reduce the sampling rate. The bags must be made of such a material as will not change the concentration of synthetic pollutant gases by more than $\pm 2\%$ after 20 minutes.
2.4	Additional sampling unit for the testing of vehicles equipped with a compression ignition engine
2.4.1	By way of a departure from the taking of gas samples from vehicles equipped with spark-ignition engines, the hydrocarbon and particulate sampling points are located in a dilution tunnel.
2.4.2	In order to reduce heat losses in the exhaust gases between the exhaust tail pipe and the dilution tunnel inlet, the pipe may not be more than 3.6 m long, or 6.1 m long if heat insulated. Its internal diameter may not exceed 105 mm.
2.4.3	Predominantly turbulent flow conditions (Reynolds number $> 4000$ ) must apply in the dilution tunnel, which consist of a straight tube of electrically-conductive material, in order to guarantee that the diluted exhaust gas is homogeneous at the sampling points and that the samples consist of representative gases and particulate. The dilution tunnel must be at least 200 mm in diameter and the system must be earthed.
2.4.4	The particulate sampling system consist of a sampling probe in the dilution tunnel and two series-mounted filters. Quick-acting are located both up and downstream of the two filters in the direction of flow. The configuration of the sample probe must be as indicated in Figure 4
2.4.5	The participate sampling probe must be arranged as follows :  It must be installed in the vicinity of the tunnel centerline, roughly 10 tunnel diameters downstream of the gas inlet, and have an internal diameter of at least 12 mm.

	The distance from the sampling tip to the filter mount must be at least five probe diameters, but must not exceed 1020 mm
2.4.6	<p>The sample gas flow-measuring unit consists of pumps, gas flow regulators and flow measuring units.</p> <p style="text-align: center;"><b>Figure 4 : Particulate Sampling Probe Configuration</b>  (*) Minimum internal diameter  Wall thickness : ~1 mm; Material: Stainless Steel</p>
2.4.7	The hydrocarbon sampling system consists of a heated sampling probe, line, filter and pump. The sampling probe must be installed in such a way, at the same distance from the exhaust gas inlet as the particulate sampling probe, that neither interferes with samples taken by the other. It must have a minimum internal diameter of 4 mm.
2.4.8	All heated parts must be maintained at a temperature of 463 K (190 °C) ± 10 K by heating system.
2.4.9	If it is not possible to compensate for variations in the flow rate there must be a heat exchanger and a temperature control device as specified in 2.3.3.1 above so as to ensure that the flow rate in the system is constant and the sampling rate is accordingly proportional.
3.0	Description of Devices:
3.1	Variable Dilution Device with Positive Displacement Pump (PDP-CVS) (Fig. 5).
3.1.1	The Positive Displacement Pump - Constant Volume Sampler (PDP-CVS) satisfies the requirements by metering at a constant temperature and pressure through the pump. The total volume is measured by counting the revolutions made by the calibrated positive displacement pump. The proportional sample is achieved by sampling with pump, flow meter and flow control valve at a constant flow rate.
3.1.2	Fig. 5 is a schematic drawing of such a sampling system. Since various configurations can produce accurate results, exact conformity with the drawings is not essential. Additional components such as instruments, valves, solenoids, and switches may be used

	to provide additional information and co-ordinate the functions of the component system.
3.1.3	The collecting equipment shall consist of:
3.1.3.1	A filter (B) for the dilution air, which can be preheated, if necessary. This filter shall consist of activated charcoal sandwiched between two layers of paper, and shall be used to reduce and stabilise the hydrocarbon concentrations of ambient emissions in the dilution air.
3.1.3.2	A mixing chamber (M) in which exhaust gas and air are mixed homogeneously.
3.1.3.3	A heat exchanger (H) of a capacity sufficient to ensure that throughout the test the temperature of the air/exhaust gas mixture measured at a point immediately upstream of the positive displacement pump is within $\pm 6$ K of the designed operating temperature. This device shall not affect the pollutant concentrations of diluted gases taken off for analysis.
3.1.3.4	A temperature control system (TC), used to preheat the heat exchanger before the test and to control its temperature during the test, so that deviations from the designed operating temperature are limited to $\pm 6$ K.
3.1.3.5	The positive displacement pump (PDP), used to transport a constant volume flow of the air / exhaust gas mixture. The flow capacity of the pump shall be large enough to eliminate water condensation in the system under all operating conditions which may occur during a test, this can be generally ensured by using a positive displacement pump with an adequate flow capacity.
3.1.3.5.1	Twice as high as the maximum flow of exhaust gas produced by accelerations of the driving cycle or
3.1.3.5.2	Sufficient to ensure that the CO <sub>2</sub> concentration in the dilute exhaust sample bag is less than 3 % by volume for reference diesel, less than 2.2%, cylinder for LPG and less than 1.5% cylinder for NG.
3.1.3.6	A temperature sensor (Ti) (accuracy and precision $\pm 1$ K) fitted at a point immediately upstream of the positive displacement pump. It shall be designed to monitor continuously the temperature of diluted exhaust gas mixture during the test.
3.1.3.7	A pressure gauge (Gi) (accuracy and precision $\pm 0.4$ kPa) fitted immediately upstream of the volume meter and used to register the pressure gradient between the gas mixture and the ambient air.
3.1.3.8	Another pressure gauge (Gi) (accuracy and precision $\pm 0.4$ kPa) fitted so that the differential pressure between pump inlet and pump outlet can be registered.
3.1.3.9	Two sampling outlets (S <sub>1</sub> and S <sub>2</sub> ) for taking constant samples of the dilution air and of the diluted exhaust gas/air mixture.
3.1.3.10	A filter (F), to extract solid particles from the flow of gas collected for analysis.

3.1.3.11	Pumps (P), to collect a constant flow of the dilution air as well as of the diluted exhaust-gas/air mixture during the test
3.1.3.12	Flow controllers (N), to ensure a constant uniform flow of the gas samples taken during the course of the test from sampling probes S <sub>1</sub> and S <sub>2</sub> , and flow of the gas samples shall be such that, at the end of each test, the quantity of the samples is sufficient for analysis (about 10l/min.)
3.1.3.13	Flow meters (FL), for adjusting and monitoring the constant flow of gas samples during the test.
3.1.3.14	Quick-acting valves (V), to divert a constant flow of gas samples into the sampling bags or to the outside vent.
3.1.3.15	Gas-tight, quick-lock coupling elements (Q) between the quick-acting valves and the sampling bags; the coupling shall close automatically on the sampling-bag side; as an alternative, other ways of transporting the samples to the analyser may be used (three-way stopcocks, for instance).
3.1.3.16	Bags (B), for collecting samples of the diluted exhaust gas and of the dilution air during the test. They shall be of sufficient capacity not to impede the sample flow. The bag material shall be such as to affect neither the measurements themselves nor the chemical composition of the gas samples (for instance: laminated polyethylene/poly amide films, or fluorinated polyhydrocarbons).
3.1.3.17	A digital counter (C), to register the number of revolutions performed by the positive displacement pump during the test.
3.1.4	Additional equipment required when testing diesel engined vehicles.
3.1.4.1	<p>The additional components shown within the dotted lines of Fig.5 shall be used when testing Diesel Engined Vehicles.</p> <p>F<sub>h</sub> is a heated filter</p> <p>S<sub>3</sub> is a sample point close to the mixing chamber</p> <p>V<sub>h</sub> is a heated multiway valve</p> <p>Q is a quick connector to allow the ambient air sample BA to be analysed on the HFID</p> <p>HFID is a heated flame, ionization analyser.</p> <p>R&amp;I are means of integrating and recording the instantaneous hydrocarbon concentrations.</p> <p>L<sub>h</sub> is a heated sample line</p>

	<p>All heated components will be maintained at 463 K (190 °C) ± 10 K.</p> <p>Particulate sampling system :</p> <p>S4 Sampling probe in the dilution tunnel</p> <p>F<sub>P</sub> Filter unit consisting of two series mounted filters:Switching arrangement for further parallel mounted pairs of filters, Sampling line,</p> <p>Pumps, flow regulators, flow measuring units.</p>
3.2	Critical-flow venturi dilution device/(CFV-CVS) (Fig. 6).
3.2.1	Using a critical-flow venturi in connection with the CVS sampling procedure is based on the principles of flow mechanics for critical flow. The variable mixture flow rate of dilution and exhaust gas is maintained at sonic velocity which is directly proportional to the square root of the gas temperature. Flow is continually monitored, computed, and integrated over the test. If an additional critical-flow sampling venturi is used the proportionality of the gas samples taken is ensured. As both pressure and temperature are equal at the two venturi inlets, the volume of the gas flow diverted for sampling is proportional to the total volume of diluted exhaust gas mixture produced, and thus the requirements of this test are met.
3.2.2	Fig. 6 is a schematic drawing of such a sampling system. Since various configurations can produce accurate results, exact conformity with the drawing is not essential. Additional components such as instruments, valve, solenoids, and switches may be used to provide additional information and co-ordinate the functions of the component system.
3.2.3	The collecting equipment shall consist of:
3.2.3.1	A filter (D), for the dilution air, which can be preheated if necessary; the filter shall consist of activated charcoal sandwiched between layers of paper, and shall be used to reduce and stabilize the hydrocarbon background emission of the dilution air.
3.2.3.2	A mixing chamber (M), in which exhaust gas and air are mixed homogeneously.
3.2.3.3	A cyclone separator (CS), to extract particles.
3.2.3.4	Two sampling probes (S <sub>1</sub> and S <sub>2</sub> ), for taking samples of the dilution air as well as of the diluted exhaust gas.
3.2.3.5	A sampling critical flow venturi (SV), to take proportional samples of the diluted exhaust gas at sampling probe, S <sub>2</sub> .



3.2.3.6	A filter (F), to extract solid particles from the gas flows diverted for analysis.
3.2.3.7	Pumps (P), to collect part of the flow of air and diluted exhaust gas in bags during the test.
3.2.3.8	A flow controller (N), to ensure a constant flow of the gas samples taken in the course of the test from sampling probe S <sub>1</sub> . The flow of the gas samples shall be such, that at the end of the test, the quantity of the samples is sufficient for analysis (about 10l/min)
3.2.3.9	Flow meters (FL), for adjusting and monitoring the flow of gas samples during tests.
3.2.3.10	A scrubber (PS), in the sampling line.
3.2.3.11	Quick-acting solenoid valves (V), to divert a constant flow of gas samples into the sampling bags or to the vent.
3.2.3.12	Gas-tight, quick-lock coupling elements (Q), between the quick acting valves and the sampling bags; the couplings shall close automatically on the sampling bag side. As an alternative, other ways of transporting the samples to the analyser may be used (three-way stopcock, for instance).
3.2.3.13	Bags (B), for collecting samples of the diluted exhaust gas and the dilution air during the test; they shall be of sufficient capacity not to impede the sample flow. The bag material shall be such as to affect neither the measurements themselves nor the chemical composition of the gas samples (for instance, laminated polyethylene/polyamide films, or fluorinated polyhydrocarbons).
3.2.3.14	A pressure gauge (G), which shall be precise and accurate to within $\pm 0.4$ kPa.
3.2.3.15	A temperature sensor (T), which shall be precise and accurate to within $\pm 1$ K and have a response time of 0.1 seconds to 62 % of a temperature change (as measured in silicon oil).
3.2.3.16	A measuring critical flow venturi tube (MV), to measure the flow volume of the diluted exhaust gas.
3.2.3.17	A blower (BL), of sufficient capacity to handle the total volume of diluted gas.
3.2.3.18	The capacity of the CFV-CVS system shall be such that under all operating conditions which may possibly occur during a test there will be no condensation of water. This is generally ensured by using a blower whose capacity is;
3.2.3.18.1	Twice as high as the maximum flow of exhaust gas produced by accelerations of the driving cycle or
3.2.3.18.2	Sufficient to ensure that the CO <sub>2</sub> concentration in the dilute exhaust sample bag is less than 3 % by volume.
3.2.4	Additional equipment required when testing diesel engined vehicles.
3.2.4.1	The additional components shown within the dotted lines of Fig.10 shall be used when testing Diesel Engined Vehicles.  Fh : is a heated filter

	<p>S<sub>3</sub> : is a sample point close to the mixing chamber  V<sub>h</sub> : is a heated multiway valve  Q : is a quick connector to allow the ambient air sample BA to be analysed on the HFID  HFID : is a heated flame, ionization analyser.  R &amp; I : are means of integrating and recording the instantaneous hydrocarbon concentrations.  L<sub>h</sub> : is a heated sample line  All heated components will be maintained at 463 K (190 °C) ± 10 K.</p>
3.2.4.2	<p>If compensation for varying flow is not possible then a heat exchanger (H) and temperature control system (TC) as described in Paragraph 2.2.3 of this Chapter will be required to ensure constant flow through the ventury (MV) and thus proportional flow through S<sub>3</sub>.</p> <p>Particulate sampling system :  S<sub>4</sub> Sampling probe in dilution tunnel  F<sub>P</sub> Filter series consisting of two series mounted filters : Switching arrangement for further parallel mounted pairs of filters, sampling line,  Pumps, flow regulators, flow measuring units.</p>
3.3	Variable dilution device with constant flow control by orifice (CFO-CVS) (Fig. 7).
3.3.1	The collection equipment shall consist of:
3.3.1.1	A sampling tube connecting the vehicle's exhaust pipe to the device itself;
3.3.1.2	A sampling device consisting of a pump for drawing in the diluted mixture of exhaust gas and air;
3.3.1.3	A mixing chamber (M) in which exhaust gas and air are mixed homogeneously.
3.3.1.4	<p>A heat exchanger (H) of a capacity sufficient to ensure that throughout the test the temperature of the air/exhaust gas mixture measured at a point immediately before the positive displacement of the flow rate measuring device is within ± 6 K. This device shall not alter the pollutant concentration of diluted gases taken off for analysis. Should this condition not be satisfied for certain pollutants, sampling will be effected before the cyclone for one or several considered pollutants.</p> <p>If necessary, a device for temperature control (TC) is used to preheat the heat exchanger before testing and to keep up its temperature during the test within ± 6 K of the designed operating temperature.</p>
3.3.1.5	Two probes (S <sub>2</sub> and S <sub>2</sub> ) for sampling by means of pumps (P), flowmeters (FL) and, if necessary, filters (F) allowing for the collection of solid particles from gases used for the analysis.
3.3.1.6	One pump for dilution air and another one for diluted mixture.
3.3.1.7	A volume-meter with an orifice.

3.3.1.8	A temperature sensor (Ti) (accuracy and precision $\pm 1$ K) fitted at a point immediately before the volume measurement device. It shall be designed to monitor continuously the temperature of the diluted exhaust gas mixture during the test.
3.3.1.9	A pressure gauge (Gi) (capacity and precision $\pm 0.4$ kPa) fitted immediately before the volume meter and used to register the pressure gradient between the gas mixture and the ambient air.
3.3.1.10	Another pressure gauge (G <sub>2</sub> ) (accuracy and precision $\pm 0.4$ kPa) fitted so that the differential pressure between pump inlet and pump outlet can be registered.
3.3.1.11	Flow controllers (N) to ensure a constant uniform flow of gas samples taken during the course of the test from sampling outlets S <sub>1</sub> and S <sub>2</sub> . The flow of the gas samples shall be such that, at the end of each test, the quantity of the samples is sufficient for analysis (about 10l/min).
3.3.1.12	Flow meters (FL) for adjusting and monitoring the constant flow of gas samples during the test.
3.3.1.13	Three-way valves (V) to divert a constant flow of gas samples into the sampling bags or to the outside vent
3.3.1.14	Gas-tight, quick lock sampling elements (Q) between the three-way valves and the sampling bags. The coupling shall close automatically on the sampling bag side. Other ways of transporting the samples to the analyser may be used (three-way stopcocks, for instance).
3.3.1.15	Bags (B) for collecting samples of diluted exhaust gas and of dilution air during the test. They shall be of sufficient capacity not to impede the sample flow. The bag material shall be such as to affect neither the measurements themselves nor the chemical composition of the gas samples for instance, laminated polyethylene/poly amide films, or fluorinated polyhydrocarbons).

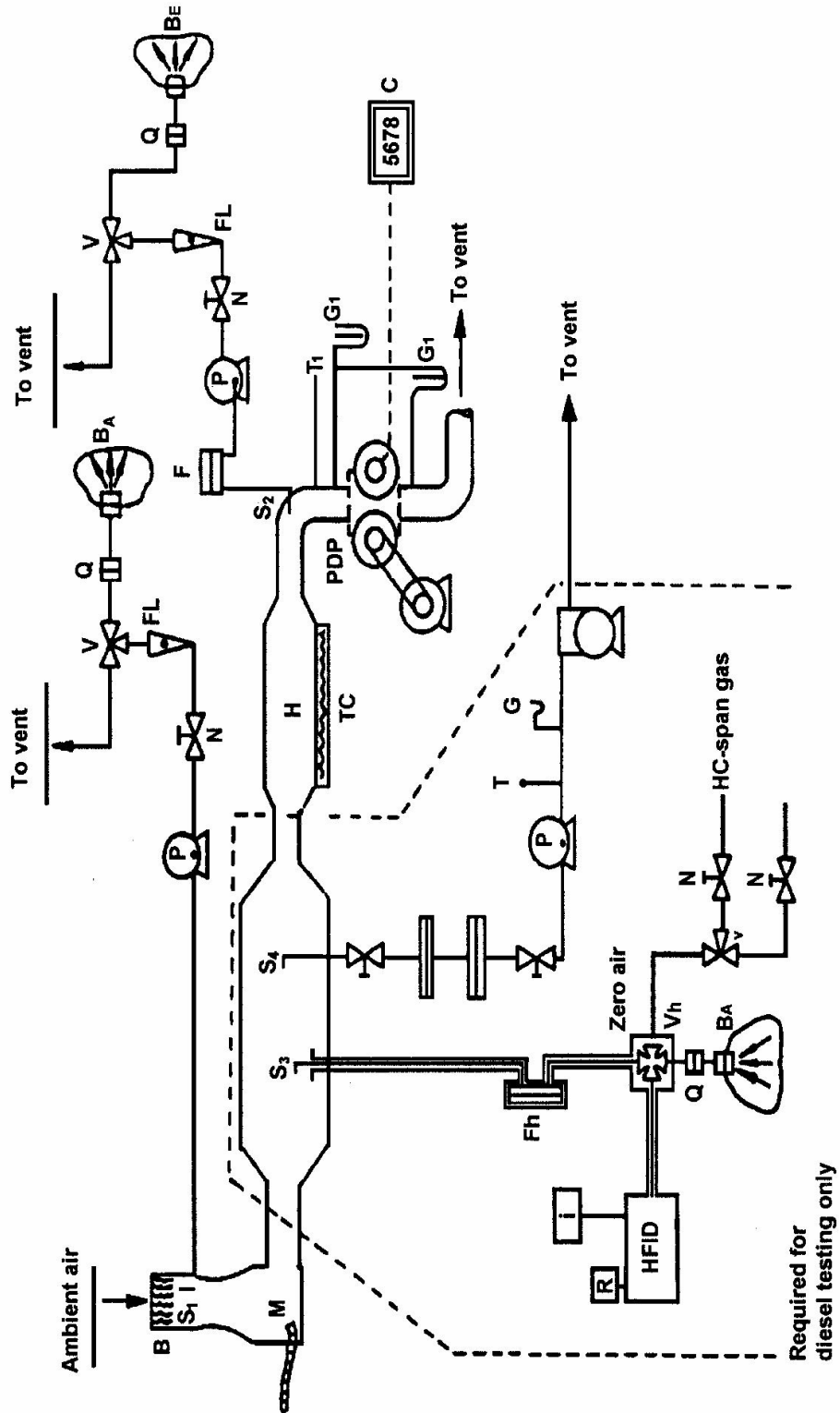

Figure 5 : Schematic Constant Volume Sampler with Positive Displacement Pump (PDP-CVS) (Pis. Ref Para. 3.1 of this Chapter)



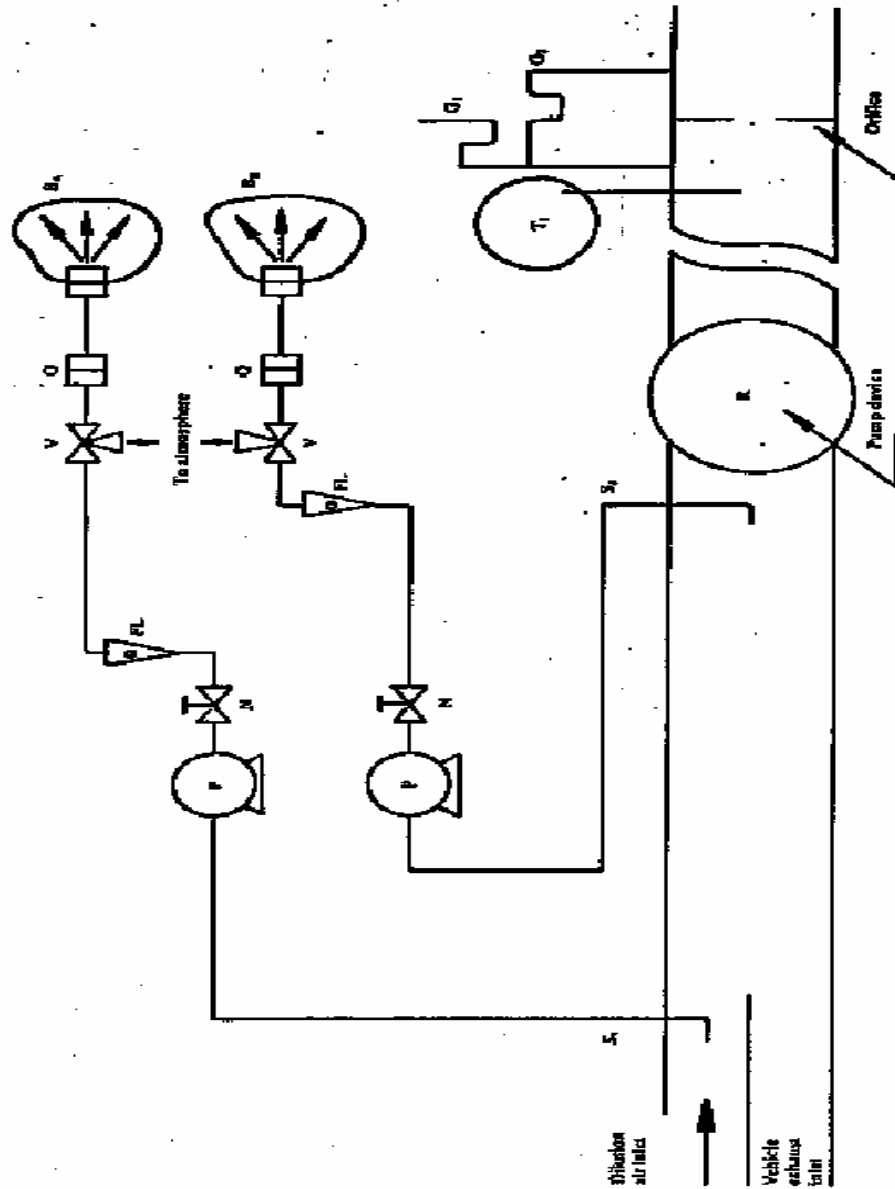

Figure 7 : Schematic of Variable Dilution Device with Constant Flow Control by Orifice (CFO-CVS)

(Pis. Ref. Para 3.3 of this Chapter)

## Chapter 7

### CALIBRATION OF CHASSIS DYNAMOMETERS, CVS SYSTEM AND GAS ANALYSIS SYSTEM AND TOTAL SYSTEM VERIFICATION

1	Scope :
1.1	This Chapter describes the methods used for calibrating, and verifying the Chassis Dynamometers, CVS System and Analysis System.
2	Methods of Calibration of Chassis Dynamometer :(The method to be used to determine the power absorbed by a dynamometric brake)
2.1	The power absorbed by chassis dynamometer comprises the power absorbed by frictional effects and the power absorbed by the power absorption device. The chassis dynamometer is brought into operation beyond the range of test speeds. The device used for starting up the chassis dynamometer is then disconnected; the rotational speed of the driven rollers decreases. The kinetic energy of rollers is dissipated by the power absorption unit and by the frictional effects. This method disregards variations in the roller's internal frictional effects caused by rollers with or without the vehicle. The frictional effects of the rear roller shall be disregarded when this is free.
2.2	Calibrating the power indicator to <b>50</b> km/h as a function the power absorbed The following procedure shall be used.(Fig. 8)
2.2.1	Measure the rotational speed of the roller if this has not already been done. A fifth wheel, a revolution counter or some other method may be used.
2.2.2.	Place the vehicle on the dynamometer or connect the device for starting up the dynamometer.
2.2.3	Use the fly-wheel or any other system of inertia simulation for the particular inertia class to be used.
2.2.4	Bring the dynamometer to a speed of <b>50</b> km/h.
2.2.5	Note the power indicated (Pi).
2.2.6	Bring the dynamometer to a speed of <b>60</b> km/h.
2.2.7	Disconnect the device used to start up the dynamometer.
2.2.8	Note the time taken by the dynamometer to pass from a speed of 55 km/h to a speed of 45 km/h.
2.2.9	Set the power absorption device at a different level.
2.2.10	The requirements of paragraphs 2.2.4 to 2.2.9 above shall be repeated sufficient number of times to cover the range of road power used.
2.2.11	Calculate the power absorbed, using the formula: $P_a = M_i * \frac{V_1^2 - V_2^2}{2000t}$ <p>Where  P<sub>a</sub> = power absorbed in kW  M<sub>i</sub> = equivalent inertia in kg (excluding the inertial effects of the free rear roller)</p>

	<p><math>V_1</math> = initial speed in m/s (55 km/h = 15.28 m/s)  <math>V_2</math> = final speed in m/s (45 km/h = 12.50 m/s)  <math>t</math> = time taken by the roller to pass from 55 km/h to 45 km/h in s.</p>
2.2.11.1	<p>The requirements of paragraphs 2.2.3 to 2.2.11 shall be repeated for all inertia classes to be used.</p> <div style="text-align: center;"> <p>▲ = <math>F = a + b.V^2</math>      ● = <math>(a + b.V^2) - 0.1.F_{R0}</math>      □ = <math>(a + b.V^2) + 0.1.F_{R0}</math></p> </div> <p style="text-align: center;"><b>Figure 8 : Diagram illustrating the load of the chassis dynamometer</b></p>
2.3.	<p>Calibration of the power indicator as a function of the absorbed power for other speeds :  The procedures of paragraph 2.2 shall be repeated sufficient number of times for the chosen speeds.</p>
2.4.	<p>Verification of the power-absorption curve of the roller bench from a reference setting to a speed of <b>50 km/h</b> :</p>
2.4.1	<p>Place the vehicle on the dynamometer or devise some other method of starting up the dynamometer.</p>
2.4.2	<p>Adjust the dynamometer to the absorbed power <math>P_a</math>, at 50 km/h.</p>
2.4.3	<p>Note the power absorbed at 50,40,30 and 20 km/h.</p>
2.4.4	<p>Draw the curve <math>P_a</math> versus <math>V</math> and verify that it meets the requirements of 6.1.1. of Chapter 4 of this part.</p>
2.4.5	<p>Repeat the procedure of para 2.4.1 to 2.4.4 for other values of power <math>P_a</math> at 50 km/h and for other values of inertia.</p>
2.5	<p>The same procedure will be used for force or torque calibration.</p>
3	<p>Calibration of the CVS System :</p>
3.1	<p>The CVS system shall be calibrated by using an accurate flow meter and a restricting device. The flow through the system shall be measured at various pressure readings and the control parameters of the system measured and related to the flows.</p> <p>Various types of flow meter may be used, e.g. calibrated venturi, laminar flow meter, calibrated turbine meter provided that they are</p>



	dynamic measurement systems and can meet the requirements of paragraphs 4.2.2 and 4.2.3 of Chapter 3 of this part.						
3.1.1	The following sections give details of methods of calibrating PDP and CFV units, using a laminar flow meter, which gives the required accuracy, together with a statistical check on the calibration validity.						
3.2	Calibration of the Positive Displacement Pump (PDP) :						
3.2.1	The following calibration procedure outlines the equipment the test configuration, and the various parameters which shall be measured to establish the flow rate of the CVS-pump. All the parameters related to the pump are simultaneously measured with the parameters related to the flow meter which is connected in series with pump. The calculated flow rate (given in m <sup>3</sup> /min at pump inlet, absolute pressure and temperature) can then be plotted versus a correlation function which is the value of a specific combination of pump parameters. The linear equation which relates the pump and the correlation function is then determined. In the event that a CVS has a multiple speed drive, a calibration for each range used shall be performed.						
3.2.2	This calibration procedure is based on the measurement of the absolute values of the pump and flow meter parameters that relate the flow rate at each point. Three conditions must be maintained to ensure the accuracy and integrity of the calibration curve as given below :						
3.2.2.1	The pump pressures shall be measured at tappings on the pump rather than at the external piping on the pump inlet and outlet. Pressure taps that are mounted at the top centre and bottom centre of the pump drive headplate are exposed to the actual pump cavity pressures, and therefore reflect the absolute pressure differentials.						
3.2.2.2	Temperature stability shall be maintained during the calibration. The laminar flow meter is sensitive to inlet temperature oscillations which cause the data points to be scattered. Gradual changes of $\pm 1$ K in temperature are acceptable as long as they occur over a period of several minutes.						
3.2.2.3	All connections between the flow meter and the CVS pump shall be free of any leakage. 3.2.3 During an exhaust emission test, the measurement of these same pump parameters enables the user to calculate the flow rate from the calibration equation.						
3.2.3.1	Fig. 9 in this chapter shows one possible test set-up. Variations are permissible, provided that they are approved by the Authority granting the approval as being of comparable accuracy. If the set-up shown in Fig.3 is used, the following data shall be found within the limits of precision given :  <table border="0" style="width: 100%;"> <tr> <td style="width: 70%;">Barometric pressure (corrected (PB))</td> <td style="text-align: right;"><math>\pm 0.03</math> kPa</td> </tr> <tr> <td>Ambient temperature (T)</td> <td style="text-align: right;"><math>\pm 0.2</math> K</td> </tr> <tr> <td>Air temperature at LFE (ETI)</td> <td style="text-align: right;"><math>\pm 0.15</math> K</td> </tr> </table>	Barometric pressure (corrected (PB))	$\pm 0.03$ kPa	Ambient temperature (T)	$\pm 0.2$ K	Air temperature at LFE (ETI)	$\pm 0.15$ K
Barometric pressure (corrected (PB))	$\pm 0.03$ kPa						
Ambient temperature (T)	$\pm 0.2$ K						
Air temperature at LFE (ETI)	$\pm 0.15$ K						

	<p>Pressure depression upstream of LFE(EPI) <math>\pm 0.01</math> kPa</p> <p>Pressure drop across the LFE matrix (EDP) <math>\pm 0.0015</math> kPa</p> <p>Air temperature at CVS pump inlet (PTI) <math>\pm 0.2</math> K</p> <p>Air temperature at CVS pump outlet (PTO) <math>\pm 0.2</math> K</p> <p>Pressure depression at CVS pump inlet (PPI) <math>\pm 0.22</math> kPa</p> <p>Pressure head at CVS-pump outlet (PPO) <math>\pm 0.22</math> kPa</p> <p>Pump revolutions during test period (n) <math>\pm 1</math> rev.</p> <p>Elapsed time for period (min 250 sec) (t) <math>\pm 0.1</math> sec</p>
3.2.3.2	After the system has been connected, as shown in Fig 9, the variable restrictor is set in the wide-open position and the CVS pump run for 20 minutes before starting the calibration.
3.2.3.3	The restrictor valve is adjusted in steps to get an increment of pump inlet depression (about 1 kPa) that will yield a minimum of six data points for the total calibration. The system is allowed to stabilize for three minutes and the data acquisition repeated.
3.2.4	Data analysis :
3.2.4.1	The air flow rate, $Q_s$ , at each test point is calculated in standard m <sup>3</sup> /min from the flow meter data using the manufacturer's prescribed method.
3.2.4.2	<p>The air flow rate is then converted to pump flow, <math>V_o</math>, in m<sup>3</sup> per revolution at absolute pump inlet temperature and pressure.</p> $V_o = \frac{Q_s}{n} * \frac{T_p}{293} * \frac{101.33}{P_p}$ <p>Where,</p> <p><math>V_o</math> = pump flow rate at <math>T_p</math> and <math>P_{p0}</math> given in m<sup>3</sup> /rev</p> <p><math>Q_s</math> = air flow at 101.33 kPa and 293 K given in m<sup>3</sup> /min</p> <p><math>T_p</math> = pump inlet temperature (K)</p> <p><math>P_p</math> = absolute pump inlet pressure, in kPa</p> <p><math>n</math> = pump speed in revolutions per minute</p> <p>To compensate the interaction of pump speed, pressure variations at the pump and the slip rate, the correlation function (<math>X_o</math>) between the pump speed (<math>n</math>), the pressure differential from the pump inlet to pump outlet and the absolute pump outlet Pressure is then calculated as follows :-</p>

	$X_o = \frac{1}{n} * \sqrt{\frac{\Delta P_p}{P_e}}$ <p>Where,</p> <p>X<sub>o</sub> = correlation function</p> <p>ΔP<sub>p</sub> = pressure differential from pump inlet to pump outlet (kPa)</p> <p>P<sub>e</sub> = absolute pump outlet pressure (PPO + PB) (kPa)</p> <p>A linear least square fit is performed to generate the calibration equations which have the formula</p> $V_o = V_o = D_o - M(X_o)$ $n = A - B(\Delta P_p)$ <p>where -</p> <p>D<sub>o</sub>, M, A and B are the slope-intercept constants describing the lines.</p>
3.2.4.3	<p>A CVS system that has multiple speeds shall be calibrated on each speed used. The calibration curves generated for the ranges should be approximately parallel and the intercept values, (D<sub>o</sub>) should increase as the pump flow decreases.</p>
3.2.4.4	<p>If the calibration has been performed carefully, the calculated values from the equation should be within ±0.5 % of the measured value of V<sub>o</sub>. Values of M should vary from one pump to another. Calibration shall be performed at pump start-up and after major maintenance.</p>
3.3	<p>Calibration of the Critical-Flow Venturi (CFV) (Fig. 10)</p>
3.3.1	<p>Calibration of the CFV is based upon the flow equation for a critical venturi</p> $Q_s = K_v * \frac{P}{\sqrt{T}}$ <p>Where,</p> <p>Q<sub>s</sub> = Flow rate in m<sup>3</sup> / min at 101.33 kPa and 293 K</p> <p>K<sub>v</sub> = Calibration coefficient</p> <p>P = Absolute pressure (kPa)</p> <p>T = Absolute temperature ( K)</p> <p>Gas flow is a function of inlet pressure and temperature. The calibration procedure described below establishes the value of the calibration coefficient at measured value of pressure, temperature and air flow.</p>

3.3.2	The manufacturer's recommended procedure shall be followed for calibrating electronic portions of the CFV.														
3.3.3	<p>Measurements for flow calibration of the critical flow venturi are required and the following data shall be found within the limits of precision given :</p> <table data-bbox="391 401 1372 877"> <tr> <td>Barometric pressure (corrected) (P<sub>B</sub>)</td> <td>± 0.03 kPa</td> </tr> <tr> <td>LFE air temperature flowmeter (ETI)</td> <td>± 0.15 K</td> </tr> <tr> <td>Pressure depression up-stream of LFE (EPI)</td> <td>± 0.01 kPa</td> </tr> <tr> <td>Pressure drop across (EDP) LFE matrix</td> <td>± 0.0015 kPa</td> </tr> <tr> <td>Air Flow (Q<sub>s</sub>)</td> <td>± 0.5 %</td> </tr> <tr> <td>CFV inlet depression (PPI)</td> <td>± 0.02 kPa</td> </tr> <tr> <td>Temperature at venturi inlet (T<sub>v</sub>)</td> <td>± 0.2 K</td> </tr> </table>	Barometric pressure (corrected) (P <sub>B</sub> )	± 0.03 kPa	LFE air temperature flowmeter (ETI)	± 0.15 K	Pressure depression up-stream of LFE (EPI)	± 0.01 kPa	Pressure drop across (EDP) LFE matrix	± 0.0015 kPa	Air Flow (Q <sub>s</sub> )	± 0.5 %	CFV inlet depression (PPI)	± 0.02 kPa	Temperature at venturi inlet (T <sub>v</sub> )	± 0.2 K
Barometric pressure (corrected) (P <sub>B</sub> )	± 0.03 kPa														
LFE air temperature flowmeter (ETI)	± 0.15 K														
Pressure depression up-stream of LFE (EPI)	± 0.01 kPa														
Pressure drop across (EDP) LFE matrix	± 0.0015 kPa														
Air Flow (Q <sub>s</sub> )	± 0.5 %														
CFV inlet depression (PPI)	± 0.02 kPa														
Temperature at venturi inlet (T <sub>v</sub> )	± 0.2 K														
3.3.4	The equipment shall be set up as shown in fig. 10 and checked for leaks. Any leaks between the flow measuring device and the critical flow venturi will seriously affect the accuracy of the calibration.														
3.3.5	The variable flow restrictor shall be set to the "open" position, the blower shall be started and the system shall be stabilised. Data from all instruments shall be recorded.														
3.3.6	The flow restrictor shall be varied and at least eight readings across the critical flow range of the venturi shall be made.														
3.3.7	<p>The data recorded during the calibration shall be used in the following calculations. The air flow rate, Q<sub>s</sub>, at each test point is calculated from the flow meter data using the manufacturer's prescribed method.</p> <p>Values of the calibration coefficient K<sub>v</sub> for each test point is calculated as below –</p> $K_v = \frac{Q_s * \sqrt{T_v}}{P_v}$ <p>Where,</p> <p>Q<sub>s</sub> = flow rate in m<sup>3</sup> /min at 293 K and 101.33 kPa</p> <p>T<sub>v</sub> = temperature at the venturi inlet ( K)</p> <p>P<sub>v</sub> = absolute pressure at the venturi inlet (kPa)</p>														

	<p>Plot <math>K_v</math> as a function of venturi inlet pressure. For sonic flow <math>K_v</math> will have a relatively constant value. As pressure decreases (vacuum increases) the venturi becomes unchoked and <math>K_v</math> decreases.</p> <p>The resultant <math>K_v</math> changes are not permissible.</p> <p>For a minimum of eight points in the critical region calculate the average <math>K_v</math> and the standard deviation.</p> <p>If the standard deviation exceeds 0.3 % of the average <math>K_v</math>, corrective action shall be taken.</p>
4	Calibration of Gas Analysis System :
4.1.	Establishment of Calibration Curve
4.1.1	The analyser calibration curve shall be established by at least five calibration points, spaced as uniformly as possible. The nominal concentration of the calibration gas of the highest concentration shall be at least equal to 80% of the full scale.
4.1.2	The calibration curve is calculated by the least square method. If the degree of the polynomial resulting from the curve is greater than 3, the number of calibration points shall be at least equal to this polynomial degree plus 2.
4.1.3	The calibration curve shall not differ by more than 2% from the nominal value of calibration gas of each calibration point.
4.1.4	The different characteristic parameters of the analyser, particularly, the scale, the sensitivity, the zero point and the date of carrying out the calibration should be indicated on the calibration curve.
4.1.5	It can be shown to the satisfaction of the testing authority, that alternative technology e.g. computer, electronically controlled range switch etc., can give equivalent accuracy, then these alternatives may be used.
4.2	Verification of Calibration
4.2.1	The calibration procedure shall be carried out as often as necessary and in any case within one month preceding the type approval emission test and once in six months for verifying conformity of production.
4.2.2	The verification should be carried out using standard gases. The same gas flow rates shall be used as when sampling exhaust.
4.2.3	A minimum of two hours shall be allowed for warming up the analysers.
4.2.4	The NDIR analyser shall be tuned, where appropriate, and the flame combustion of the FID analyser optimised.
4.2.5	Using purified dry air ( or nitrogen ), the CO and NOx analysers shall be set at zero; dry air shall be purified for the HC analyser. Using appropriate calibrating gases mentioned in 4.5 of Chapter 3 of this part, the analysers shall be reset.
4.2.6	The zero setting shall be rechecked and the procedure described in Para 4.2.4 and 4.2.5 above repeated, if necessary.
4.2.7	The calibration curves of the analysers should be verified by checking at least at five calibration points, spaced as uniformly as possible. The

	nominal concentration of the calibration gas of the highest concentration shall be at least equal to 80% of the full scale. It should meet the requirement of para 4.1.3 above.
4.2.8	If it does not meet, the system should be checked, fault, if any, corrected and a new calibration curve should be obtained.
4.3	Pre-test Checks
4.3.1	A minimum of two hours shall be allowed for warming up the infra-red NDIR analyser, but it is preferable that power be left on continuously in the analysers. The chopper motors may be turned off when not in use.
4.3.2	Each normally used operating range shall be checked prior to each analysis.
4.3.3	Using purified dry air ( or nitrogen ), the CO and NOx analysers shall be set at zero; dry air shall be purified for the HC analyser.
4.3.4	Span gas having a concentration of the constituent that will give a 75-95% full-scale deflection shall be introduced and the gain set to match the calibration curve. The same flow rate shall be used for calibration, span and exhaust sampling to avoid correction for sample cell pressure.
4.3.5	The nominal value of the span calibration gas used shall remain within $\pm 2\%$ of the calibration curve.
4.3.6	If it does not, but it remains within $\pm 5\%$ of the calibration curve, the system parameters such as gain of the amplifier, tuning of NDIR analysers, optimisation of FID analysers etc. may be adjusted to bring within $\pm 2\%$ .
4.3.7	If the system does not meet the requirement of 4.3.5 and 4.3.6 above, the system should be checked, fault, if any corrected and a new calibration curve should be obtained.
4.3.8	Zero shall be checked and the procedures described in para 4.3.4 above repeated, if required.
4.4	Post test checks :
	After testing zero gas and the span gas shall be used for re-checking. The analysis is considered acceptable if the difference between two measuring results is less than 2%.
4.5	Check for FID Hydrocarbon Response
4.5.1	Detector response optimization :  The FID shall be adjusted as specified by the instrument manufacturer. Propane in air shall be used to optimize the response, on the most common operating range.
4.5.2	Response factor of different hydrocarbons and recommended limits
4.5.2.1	The response factor ( $R_f$ ) for a particular hydrocarbon species is the ratio of the FID $C_1$ reading to the gas cylinder concentration, expressed as ppm $C_1$ .
4.5.2.2	The concentration of the test gas shall be at a level to give a response of approximately 80% of full scale deflection for the operating range. The concentration shall be known to an accuracy of $\pm 2\%$ in reference to a gravimetric standard expressed in volume. In addition, the gas

	cylinder shall be preconditioned for 24 hours at a temperature between 293 & 303 K (20°C and 30°C).
4.5.2.3	<p>Response factors are to be determined when introducing an analyser into service and thereafter at major service intervals. The test gases to be used and the recommended response factors are :</p> <p>For methane and purified air <math>1.00 &lt; R_f &lt; 1.15</math>, or <math>1.00 &lt; R_f &lt; 1.05</math> for NG fuelled vehicles</p> <p>For propylene and purified air <math>0.90 &lt; R_f &lt; 1.00</math>,</p> <p>For toluene and purified air <math>0.90 &lt; R_f &lt; 1.00</math>,</p> <p>Relative to a response factor (<math>R_f</math>) of 1.00 for propane and purified air.</p>
4.5.3	<p>Oxygen interference check and recommended limits</p> <p>The response factor shall be determined as described in 4.5.2. The test gas to be used and recommended response factor range are :</p> <p>Propane and nitrogen <math>0.95 \leq R_f \leq 1.05</math>,</p>
4.6	Efficiency Test of the NO <sub>x</sub> Converter :
4.6.1	The efficiency of the converter used for the conversion of NO <sub>2</sub> into NO is tested as follows :
4.6.1.1	Using the test set up shown in Fig.11 and the procedure described below, the efficiency of converters can be tested by means of an ozonator.
4.6.2	Calibrate the CLA analyser in the most common operating range following the manufacturer's specifications using zero and span gas (the NO content of which should amount to about 80 % of the operating range and the NO <sub>2</sub> concentration of the gas mixture shall be less than 5 % of the NO concentration). The NO <sub>x</sub> analyser shall be in the NO mode so that span gas does not pass through the converter. Record the indicated concentration.
4.6.3	Via a T-fitting, oxygen or synthetic air is added continuously to the gas flow until the concentration indicated is about 10 % less than the indicated calibration concentration given in paragraph 4.5.2 above. Record the indicated concentration (c). The ozonator is kept deactivated throughout this process.
4.6.4	The ozonator is now activated to generate enough ozone to bring the NO concentration down to 20 % (minimum 10 %) of the calibration concentration given in 4.6.2. Record the indicated concentration (d).
4.6.5	The NO <sub>x</sub> analyser is then switched to the NO <sub>x</sub> mode which means that the gas mixture (consisting of NO, NO <sub>2</sub> , O <sub>2</sub> and N <sub>2</sub> ) now passes through the converter. Record the indicated concentration (a).
4.6.6	The ozonator is now deactivated. The mixture of gases described in paragraph 4.6.3 above passes through the converter into the detector. Record the indicated concentration (b).
4.6.7	With the ozonator deactivated, the flow of oxygen or synthetic air is also shut off. The NO <sub>x</sub> reading of the analyser shall then be no more than 5 % above the figure in paragraph 4.6.2
4.6.8	The efficiency of the NO <sub>x</sub> converter is calculated as follows :

	$\text{Efficiency (\%)} = \left( 1 + \frac{(a - b)}{(c - d)} \right) * 100$
4.6.9	The efficiency of the converter shall not be less than 95%.
4.6.10	The efficiency of the converter shall be tested at least once a week.
4.7	<b>System Leak Test :</b>
	A system leakage test shall be performed. The probe shall be disconnected from the exhaust system and the end plugged. The analyser pump shall be switched on. After an initial stabilisation period all flow meters and pressure gauges should read zero. If not, the sampling line(s) shall be checked and the fault corrected.
5	<b>Total System Verification :</b>
5.1	To comply with the requirements of paragraph 4.7 of Chapter 3 of this part, total accuracy of the CVS, sampling and analytical systems shall be determined by introducing a known mass of a pollutant gas into the system while it is being operated as if during a normal test and then analysing and calculating the pollutant mass according to the formulae in chapter 8 except that the density of propane shall be taken as 1.833 kg/m <sup>3</sup> at standard conditions. The following two techniques are known to give sufficient accuracy :-
5.1.1	Metering a constant flow of pure gas (CO or C <sub>3</sub> H <sub>8</sub> using a critical flow orifice device) is fed into the CVS system through the calibrated critical orifice. If the inlet pressure is high enough, the flow rate (q), which is adjusted by means of the critical flow orifice, is independent of orifice outlet pressure (critical flow). If deviations exceed by 5 %, the cause of the malfunction shall be located and determined. Then CVS system operated as in an exhaust emission test for about 5 to 10 minutes. The gas collected in the sampling bag is analysed by the usual equipment and the results compared to known quantity of pure gas.
5.2	Metering a limited quantity of pure gas ( CO or C <sub>3</sub> H <sub>8</sub> ) by means of a gravimetric technique.
5.2.1	The following gravimetric procedure may be used to verify the CVS system. The mass of a small cylinder filled with either carbon monoxide or propane is determined with a precision of ± 0.01 gram. For about 5 to 10 minutes the CVS system is operated as in a normal exhaust emission test, while CO or propane is injected into the system. The quantity of pure gas involved is determined by means of differential weighing. The gas accumulated in the bag is then analysed by means of the equipment normally used for the exhaust gas analysis. The results are then compared to the concentration figures computed previously.



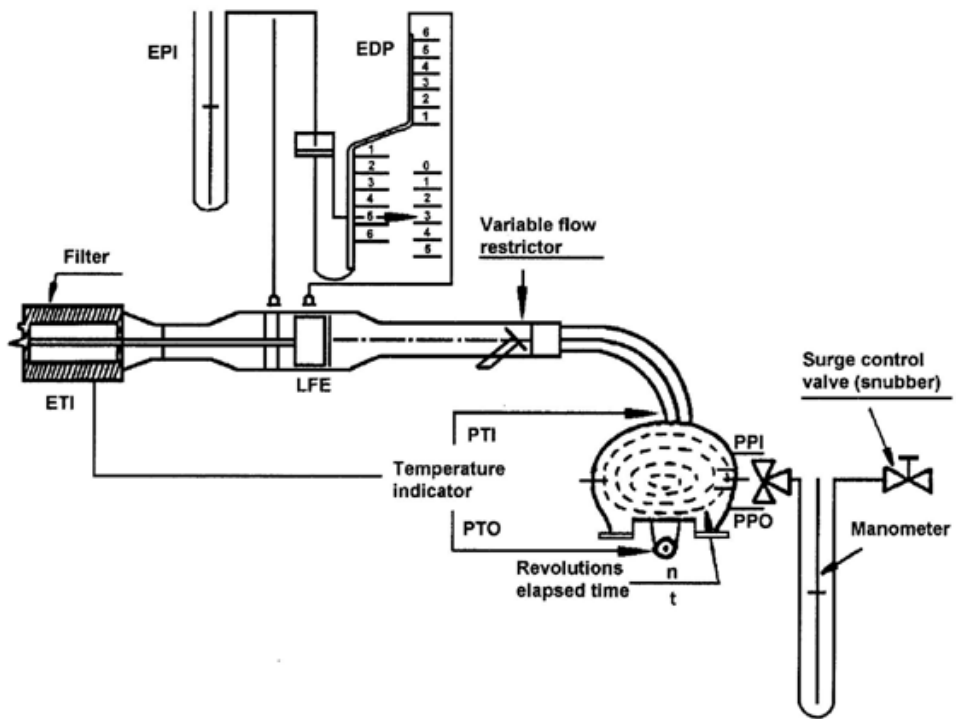

Figure 9: Schematic of PDP-CVS Calibration Set-up  
(Pis. Ref. Para. 3.2.3.1 of Chapter 7, Part IX)

Figure 10 :Schematic of CFV-CVS Calibration Set-up  
(Pis. Ref. Para. 3.3.4.of Chapter 7, Part IX)

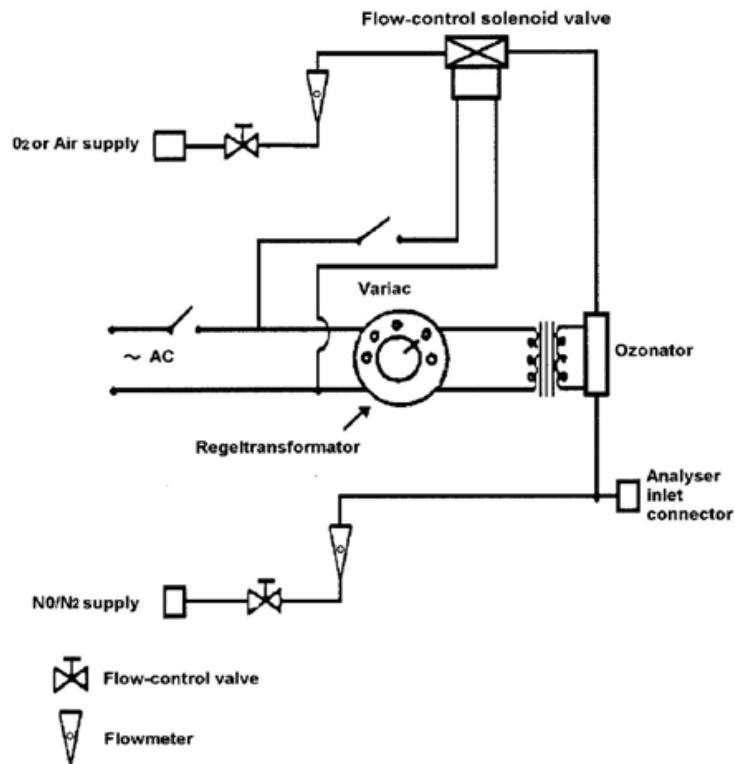
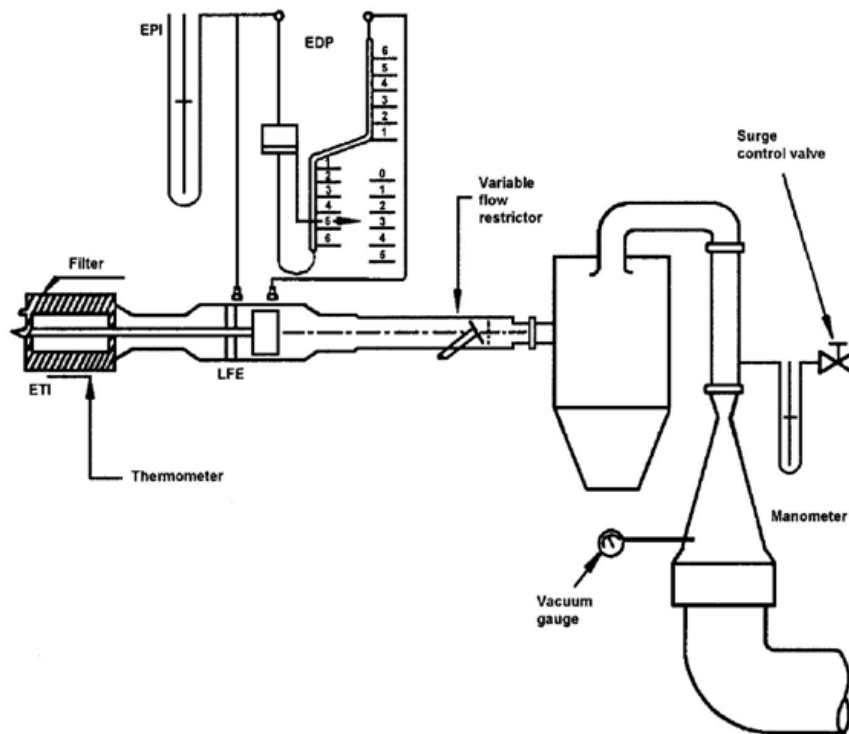

Figure 11 :Schematic of Set-up for checking the efficiency of  
NOx converter  
(Pis. Ref. Para.4.6.1.1 of Chapter 7, Part IX)

## Chapter 8

### CALCULATION OF THE MASS EMISSIONS OF POLLUTANTS AND FUEL CONSUMPTION

1	Scope : This chapter describes the calculation procedures for the mass emission of pollutants and correction for humidity for oxides of nitrogen
2	<p>The mass emission of pollutants are calculated by means of the following equation : <math>M_i = \frac{V_{mix} * Q_i * k_H * C_i * 10^{-6}}{d}</math> (1)</p> <p><math>M_i</math> = Mass emission of the pollutant i in g/km  <math>V_{mix}</math> = Volume of the diluted exhaust gas expressed in m<sup>3</sup>/test and corrected to standard conditions 293 K and 101.33 kPa  <math>Q_i</math> = Density of the pollutant i in g/m<sup>3</sup> at normal temperature and pressure (293 K and 101.33 kPa)  <math>k_H</math> = Humidity correction factor used for the calculation of the mass emissions of oxides of nitrogen.            There is no humidity correction for HC and CO  <math>C_i</math> = Concentration of the pollutant i in the diluted exhaust gas expressed in ppm and corrected by the amount of the pollutant i contained in the dilution air.  <math>d</math> = distance covered in km</p>
3.	VOLUME DETERMINATION :
3.1	Calculation of the volume when a variable dilution device with constant flow control by orifice or venturi is used. Record continuously the parameters showing the volumetric flow, and calculate the total volume for the duration of the test.
3.2	<p>Calculation of volume when a positive displacement pump is used</p> <p>The volume of diluted exhaust gas in systems comprising a positive displacement pump is calculated with the following formula</p> $V = V_o * N$ <p>where,  <math>V</math> = Volume of diluted exhaust gas expressed in m<sup>3</sup>/test (prior to correction)  <math>V_o</math> = Volume of gas delivered by the positive displacement pump on testing conditions, in m<sup>3</sup>/rev.  <math>N</math> = Number of revolutions per test.</p>
3.3	<p>Correction of the diluted exhaust gas volume to standard conditions. The diluted exhaust gas volume is corrected by means of the following formula</p> $V_{mix} = V * K_1 * \frac{P_B - P_1}{T_p} \quad (2)$ <p>in which :</p> $K_1 = \frac{293K}{101.33kPa} = 2.8915(K * kPa^{-1})$

	<p>where:  <math>P_B</math> = Barometric pressure in the test room in kPa  <math>P_1</math> = Vacuum at the inlet to the positive displacement pump in kPa relative to the ambient barometric pressure.  <math>T_P</math> = Average temperature of the diluted exhaust gas entering the positive displacement pump during the test (K).</p>
4	<p>Calculation of the Corrected Concentration of Pollutants in the Sampling Bag</p> $C_i = C_e - C_d \left(1 - \frac{1}{DF}\right) \quad (4)$ <p>where:  <math>C_i</math> = Concentration of the pollutant i in the diluted exhaust gas, expressed in ppm and corrected by the amount of i contained in the dilution air.  <math>C_e</math> = Measured concentration of pollutant i in the diluted exhaust gas, expressed in ppm.  <math>C_d</math> = Measured concentration of pollutant i in the air used for dilution, expressed in ppm.  DF = Dilution factor  The dilution factor is calculated as follows</p> $DF = \frac{13.4}{C_{CO_2} + (C_{HC} + C_{CO})10^{-4}} \quad (5a) \text{ for petrol and diesel fuels}$ $DF = \frac{11.9}{C_{CO_2} + (C_{HC} + C_{CO})10^{-4}} \quad (5b) \text{ for LPG}$ $DF = \frac{9.5}{C_{CO_2} + (C_{HC} + C_{CO})10^{-4}} \quad (5c) \text{ for Natural Gas (NG)}$ <p>where:  <math>C_{CO_2}</math> = Concentration of CO<sub>2</sub> in the diluted exhaust gas contained in the sampling bag, expressed in % volume.  <math>C_{HC}</math> = Concentration of HC in the diluted exhaust gas contained in the sampling bag, expressed in ppm carbon equivalent.  <math>C_{CO}</math> = Concentration of CO in the diluted exhaust gas contained in the sampling bag, expressed in ppm.</p>
5	<p>Determination of the NOx Humidity Correction Factor :</p>
	<p>In order to correct the influence of humidity on the results of oxides of nitrogen, the following calculations are applied</p> $k_H = \frac{1}{1 - 0.0329(H - 10.71)} \quad (6)$ <p>in which :</p> $H = \frac{6.211 * R_a * P_d}{P_B - P_d * R_a * 10^{-2}}$

	<p>where:</p> <p>H = Absolute humidity expressed in grams of water per kg of dry air</p> <p>R<sub>a</sub> = Relative humidity of the ambient air expressed in percentage</p> <p>P<sub>d</sub> = Saturation vapour pressure at ambient temperature expressed in kPa</p> <p>P<sub>B</sub> = Atmospheric pressure in the room, expressed in kPa</p>
6	Special provision relating to vehicles equipped with compression-ignition engines
6.1	<p>HC measurement for compression-ignition engines</p> <p>The average HC concentration used in determining the HC mass emissions from compression-ignition engines is calculated with the aid of the following formula</p> $C_e = \frac{\int_{t_1}^{t_2} C_{HC}.dt}{t_2 - t_1} \quad \text{-----}(7)$ <p>where:</p> <p><math>\int_{t_1}^{t_2} C_{HC}.dt</math> = Integral of the recording of the heated FID over the test (t<sub>2</sub>- t<sub>1</sub>)</p> <p>C<sub>e</sub> = concentration of HC measured in the diluted exhaust in ppm of C<sub>i</sub></p> <p>C<sub>1</sub> is substituted directly for C<sub>HC</sub> in all relevant equations.</p>
6.2	<p>Determination of particulates</p> <p>Particulate emission M<sub>p</sub> (g/km) is calculated by means of the following equation:</p> $M_p = \frac{(V_{mix} + V_{ep}) * P_e}{V_{ep} * d}$ <p>where exhaust gases are vented outside tunnel.</p> $M = \frac{V_{mix} * P_e}{V_{ep} * d}$ <p>where exhaust gases are returned to the tunnel.</p> <p>where:</p> <p>V<sub>mix</sub> : volume of diluted exhaust gases (see 2) under standard conditions</p> <p>V<sub>ep</sub> : volume of exhaust gas flowing through particulate filter under standard conditions.</p> <p>P<sub>e</sub> : particulate mass collected by filters.</p> <p>d : actual distance corresponding to the operating cycle in km.</p> <p>M<sub>p</sub> : particulate emission in g/km</p>
6.3	<b>Weighting of results from test cycles</b>

	<p>The (average) result of the cold phase called R1 ; the (average) result of the warm phase test cycle is called R2 . Using these pollutant (g/km) and CO2 (g/km) emission results, the final result R, shall be calculated using the following equations:  Equation 6.3.1:  <math>R = (R1\_cold * w1) + (R2\_warm * w2)</math>  where:  w1 = 0.3, weighting factor cold phase (30%)  w2 = 0.7, weighting factor warm phase (70%)</p>
7	<p><b>Calculation of fuel consumption</b></p>
	<p>1) The fuel consumptions are calculated by carbon balance method using measured 1.emissions of carbon dioxide (CO2) and other carbon related emissions (hydrocarbons - HC, carbon monoxide – CO)</p> <p>2) The fuel consumption expressed in km per liter ( in the case of petrol, LPG or diesel) or in km per m3 ( in the case of NG) is calculated by means of following formulae:</p> <p>I. For vehicles with a positive ignition engine fuelled with petrol:  <math>FC = 100 * D / \{(0.1154) * [(0.866 * HC) + (0.429 * CO) + (0.273 * CO2)]\}</math></p> <p>II. For vehicles with a positive ignition engine fuelled with LPG  <math>FC_{norm} = 100 * (0.538) / \{(0.1212) * [(0.825 * HC) + (0.429 * CO) + (0.273 * CO2)]\}</math></p> <p>If the composition of the fuel used for the test differs from the composition that is assumed for the calculation of the normalised consumption, on the manufacturer's request a correction factor cf may be applied, as follows:</p> $FC_{norm} = 100 * (0.538) / \{(0.1212) * (cf) * [(0.825 * HC) + (0.429 * CO) + (0.273 * CO2)]\}$ <p>The correction factor cf, which may be applied, is determined as follows:</p> $cf = 0.825 + 0.0693 * n_{actual}$ <p>where:  n<sub>actual</sub> = the actual H/C ratio of the fuel used.</p> <p>III. For vehicles with a positive ignition engine fuelled with NG</p> $FC_{norm} = 100 * (0.654) / \{(0.1336) * [(0.749 * HC) + (0.429 * CO) + (0.273 * CO2)]\}$ <p>IV. For vehicles with a compression ignition engine</p> $FC = 100 * D / \{(0.1155) * [(0.866 * HC) + (0.429 * CO) + (0.273 * CO2)]\}$ <p>In these formulae  FC = the fuel consumption in km per litre (in the case of petrol, LPG or diesel) or in km per m<sup>3</sup> (in the case of natural gas).  HC = the measured emission of hydrocarbons in g/km</p>

CO = the measured emission of carbon monoxide in g/km  
CO<sub>2</sub> = the measured emission of carbon dioxide in g/km  
D = the density of the test fuel. In the case of gaseous fuels this is the density at 15° C

For the purpose of these calculations, the fuel consumption shall be expressed in appropriate units and the following fuel characteristics shall be used,

**a)Density:** measured on the test fuel according to ISO 3675 or an equivalent method. For petrol and diesel fuel density measured at 15° C will be used; for LPG and natural gas a reference density will be used, as follows

0.538 kg/liter for LPG

0.654 kg/m<sup>3</sup> for NG\*/

\*/ Mean value of G20 and G23 reference fuels at 15°C

**b)Hydrogen -carbon ratio:** fixed values will be used which are:

1.85 for petrol

1.86 for diesel fuel

2.525 for LPG

4.00 for NG ”

## Chapter 9

### **TYPE II TEST ON SI ENGINES (VERIFYING CARBON MONOXIDE, HYDROCARBONS EMISSION AT IDLING AND CARBON MONOXIDE, LAMBDA at HIGH IDLE**

1	Scope :
	This Chapter describes the procedure for the Type II test for verifying carbon monoxide, Hydrocarbons emission at idling and verifying carbon monoxide and Lambda at High Idle of spark ignition engined vehicles, as defined in para 5.2.3 of Chapter 1 of this part.
2	Condition of Measurement
2.1	The fuel shall be the reference fuel, specifications for which are given applicable Gazette Notification under CMVR for which vehicle is subjected to test.
2.2	During the test, the environmental temperature must be between 293 and 303 K (20 and 30 degrees C). The engine shall be warmed up until all temperatures of cooling and lubrication means and the pressure of lubrication means have reached equilibrium.
2.2.1	Vehicles that are fuelled either with petrol or with LPG or NG shall be tested with the reference fuel(s) used for the type I test.
2.3	In the case of vehicle with manually operated or semi-automatic-shift gearboxes the test must be carried out with the gear lever in the 'neutral' position and with the engaged
2.4	In the case of vehicle with automatic gear-boxes the test is carried out with the gear selector in either the 'neutral' or the 'parking' position.
2.5	Components for adjusting the idling speed
2.5.1	Definition
	For the purposes of this part 'components for adjusting the idling speed' means controls for changing the idling conditions of the engine which may be easily by a mechanic using only the tools described in 2.5.1.1. In particular, devices for calibrating fuel and air flows are not considered as adjustment components if their setting requires the removal of the set-stops, an operation which cannot normally be performed except by a professional mechanic.
2.5.1.1	Tools which may be used to control components for adjusting the idling speed: screwdrivers (ordinary or cross-headed), spanners (ring, open-end of adjustable), pliers, Allen keys.
2.5.2	Determination of measurement points
2.5.2.1	A measurement at the setting in accordance with the conditions fixed by the manufacturer is performed first.
2.5.2.2	For each adjustment component with a continuous variation, a sufficient number of characteristic positions are determined.
2.5.2.3	The measurement of the carbon-monoxide content of exhaust gases must be carried out for all the possible position of the adjustment components, but for components with a continuous variation only the positions defined in 2.5.2.2 are adopted.



2.5.2.4	The Type II test is considered satisfactory if at least one of the two following conditions is met:
2.5.2.4.1	None of the values measured in accordance with 2.5.2.3 exceeds the limit values
2.5.2.4.2	The maximum content obtained by continuously varying one of the adjustment components while the other components are kept stable does not exceed the limit value, this condition being met for the various combinations of adjustment components other than the one which was varied continuously.
2.5.2.5	The possible positions of the adjustment components are limited:
2.5.2.5.1	on the one hand, by the larger of the following two values: the lowest idling speed which the engine can reach; the speed recommended by the manufacturer, minus 100 revolutions per minute;
2.5.2.5.2	on the other hand, by the smallest of the following three values: the highest speed the engine can attain by activation of the idling speed components; the speed recommended by the manufacturer, plus 250 revolutions per minute; the cut-in speed of automatic clutches.
2.5.2.6	In addition, settings incompatible with correct running of the engine must not be adopted as measurement settings. In particular, when the engine is equipped with several carburetors all carburetors must have the same setting.
3.	Sampling of Gases
3.1	The value of CO, HC concentration reading shall be recorded.
3.2	The sampling probe is placed in the pipe connecting the exhaust with the sampling bag and as close as possible to exhaust.
3.3	The concentration in CO (C <sub>co</sub> ) and CO <sub>2</sub> (C <sub>co2</sub> ) is determined from the measuring instrument readings or recordings, by use of appropriate calibration curves.
3.4	The corrected concentration for carbon monoxide regarding four-stroke engine is: <div style="border: 1px solid black; padding: 10px; width: fit-content; margin: 10px auto;"> <math display="block">C_{CO\text{corr}} = C_{CO} \frac{15}{C_{CO} + C_{CO_2}} \text{ (vol.\%)}</math> </div>
3.5	The concentration in C <sub>co</sub> (see 3.2) measured according to the formulae contained in 3.3 need not be corrected if the total of the concentrations measured (C <sub>co</sub> + C <sub>co2</sub> ) is at least 15% for four stroke engines.

## Chapter 10

### TYPE V TEST: DESCRIPTION OF THE AGEING TEST FOR VERIFYING THE DURABILITY OF ANTI POLLUTION DEVICES

#### Procedure For Durability Testing

1	Scope:																																			
	This standard covers the procedure for establishing the deterioration factor for quadricycles This procedure shall be followed in case the manufacturer does not desire to use the fixed deterioration factors specified in the corresponding emission notification.																																			
2	Mileage accumulation:																																			
2.1	Mileage accumulation may be done on road/ test track or on chassis dynamometer, at the option of the vehicle manufacturer.																																			
2.2	If the mileage accumulation is carried out on roads, the traffic on the selected road shall be such that the lap speeds can be maintained. The details of routes followed and the trends of the traffic pattern shall be recorded.																																			
2.3	If the mileage accumulation is done on a chassis dynamometer, the chassis dynamometer shall comply with the requirements given in Para 4.1.1. (Fixed load type dynamometer or given in Para 4.1.1.(Variable load chassis dynamometer) of chapter 3 of this part,. Suitable robotic controls may be used when the mileage accumulation is being carried out on a chassis dynamometer																																			
2.4	Mileage accumulation shall be exclusive of the running in period.																																			
3.0	Speeds for mileage accumulation:																																			
3.1	Mileage accumulation shall be done in laps of 6km. Atrip consisting of eleven laps is counted as one test cycle.																																			
	The following test cycles shall be followed for Quadricycles <table border="1" style="margin-left: 20px;"> <thead> <tr> <th>Vehicle type</th> <th>Engine cc</th> <th>Test Cycle classification</th> </tr> </thead> <tbody> <tr> <td>Quadricycles</td> <td>All</td> <td>A</td> </tr> </tbody> </table>	Vehicle type	Engine cc	Test Cycle classification	Quadricycles	All	A																													
Vehicle type	Engine cc	Test Cycle classification																																		
Quadricycles	All	A																																		
	The different Lap speeds for each test cycle classification is given in table 1																																			
	Table 1 Lap speeds for different Test cycle classification (See 3.1)																																			
	<table border="1" style="margin-left: 20px;"> <thead> <tr> <th rowspan="2">Test cycle classification</th> <th colspan="11">Lap speed, km/hr</th> </tr> <tr> <th>1</th> <th>2</th> <th>3</th> <th>4</th> <th>5</th> <th>6</th> <th>7</th> <th>8</th> <th>9</th> <th>10</th> <th>11</th> </tr> </thead> <tbody> <tr> <td>A</td> <td>35</td> <td>30</td> <td>35</td> <td>35</td> <td>30</td> <td>30</td> <td>30</td> <td>40</td> <td>30</td> <td>40</td> <td>40</td> </tr> </tbody> </table>	Test cycle classification	Lap speed, km/hr											1	2	3	4	5	6	7	8	9	10	11	A	35	30	35	35	30	30	30	40	30	40	40
Test cycle classification	Lap speed, km/hr																																			
	1	2	3	4	5	6	7	8	9	10	11																									
A	35	30	35	35	30	30	30	40	30	40	40																									
3.2	The break down of time vs. speed for each lap is given in Annex 1. The time versus speed is pictorially shown in Figures 1,2 and 3 for laps 1 to 9, 10 and 11 respectively.																																			

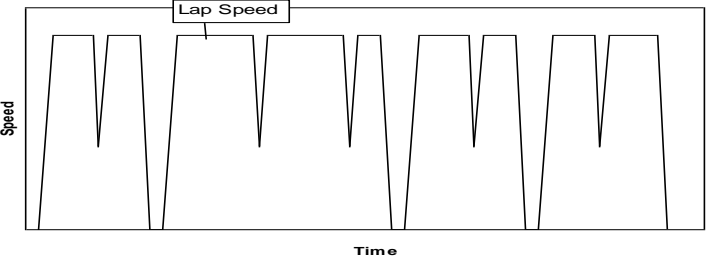
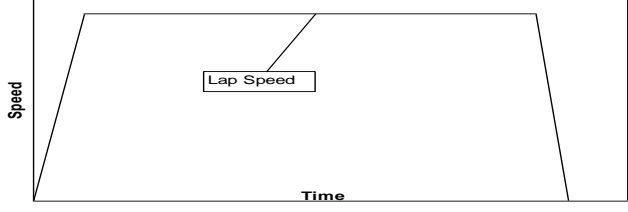
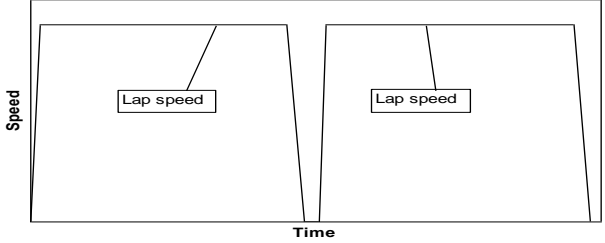
3.3	If the lap speed is not achievable because of the speed capability of the vehicle, the vehicle shall be driven at 90% of the actual maximum speed of the vehicle. In such cases, the actual lap speed followed shall be reported.
	<p style="text-align: center;"><b>Figure 1 Pictorial representation of Laps 1 to 9</b></p> 
	<p style="text-align: center;"><b>Figure 2 Pictorial representation of Lap 10</b></p> 
	<p style="text-align: center;"><b>Figure 3 Pictorial representation of Lap 11 (A)</b></p> 
4.	Gear shifting:
	During lap 1 to 10 gear shifting shall be as recommended by the manufacturer. In acceleration phase of lap 11, gearshift shall be done at the maximum safe speed of engine recommended by the manufacturer. The gear shifting pattern actually followed shall be reported for a test cycle.
5	Fuel:
	The fuel used shall comply with the requirements for the commercial fuel specified in the applicable emission regulation.
6.0	General:
6.1	If the mileage accumulation is done on a road or test track, the vehicle shall be loaded to the reference mass condition, specified in document No. MOST/CMVR/TAP115/116.
6.2	If the mileage accumulation is done on a chassis dynamometer, the load and inertia setting shall be as prescribed for the mass emission test as per document MOST/CMVR/TAP115/116 for the type approval test for specific model.

6.3	Operation of fuel enriching devices such as choke, lights etc shall be restricted as is required for the actual running of the vehicle.
6.4	The typical test cycle followed during mileage accumulation shall be reported.
7.0	Maintenance of vehicle during mileage accumulation:
7.1	Scheduled maintenance:
	A scheduled major engine tune up shall be conducted in a manner consistent with owners manual / service instructions and specifications provided by the manufacturer for use by costumer service personnel. Typical servicing items are listed below:
a)	Contact Breaker points & setting
b)	Ignition timing and setting
c)	Idle speed and Idle air/fuel mixture setting
d)	Tappet clearance
e)	Engine bolt tightening
f)	Spark plugs (Clean, gap setting, replace)
g)	Change of engine and transmission oil, change of elements for oil, air and fuel filters
h)	De-carbonization of engine including silencer in case of two stroke engines
j)	Adjustment of chains (transmission, valve train)
k)	Adjustment of control cables, clutch etc.
l)	The catalytic converter may be serviced only once during the mileage accumulation, if the failure of the catalytic converter system activates an audible and/ or visual signal which alerts the vehicle operator to the need for catalytic converter system maintenance or if the need for the periodic maintenance of the catalytic converter system is overly signalled to the vehicle operator by appropriate means, e.g., An indicator light or significantly reduced drivability performance.  The catalytic converter may be serviced as recommended by the vehicle manufacturer.)
7.2	Other maintenance:
	Certain engine components may require maintenance/replacement, which, by its nature can not be scheduled for periodic interval, but which the manufacturer believes will be necessary, shall be permitted. For example, piston and cylinder replacement caused by piston seizure, excessive wear, which results in the vehicle being inoperative
7.2.1	Any unscheduled engine, emission control system, or fuel system adjustment, repair, removal, disassembly, cleaning or replacement on vehicle shall be performed only in case of significantly reduced driving performance, subject to the following
a)	part failure or system malfunction or the repairs of such failure or malfunction does not render the vehicle unrepresentative of vehicles in use, and
b)	does not require direct access to the combustion chamber except for:

	<ul style="list-style-type: none"> <li>spark plug, fuel injection component, or</li> <li>removal or replacement of the removable pre-chamber, or decarbonising.</li> </ul>
7.2.2	Equipment, instruments or tools shall not be used to identify the malfunctioning, mal-adjustment or defective engine components unless the same or equivalent equipment, instrument or tools will be available at the dealerships and other service outlets and are used in conjunction with scheduled maintenance on such components.
7.2.3	Emission measurements shall not be used as a means of determining the need for an unscheduled maintenance
7.2.4	Repairs/replacement to vehicle components of test vehicle, other than engine, emission control system or fuel system, shall be performed only as a result of part failure, vehicle system malfunction
7.3	Records of maintenance activities: All the maintenance work carried out shall be recorded in the test report.
8	Mass emission testing during the mileage accumulation:
8.1	During the mileage accumulation the vehicle shall be tested for mass emission. Emission of CO, HC and NOx shall be measured. The measurements shall be done at the following spots:
	The first exhaust emission test shall be carried out when the mileage accumulation reaches 1500km.
	The final exhaust emission test shall be carried out when the mileage accumulation reaches the end.
	Between the first exhaust emission test and final exhaust emission test regular maintenance shall be done as recommended by the manufacturer. The gap between the maintenance shall not be less than 2000km. At least one maintenance shall be carried out during the durability test. Tests shall be carried out before and after each regular maintenance.
	Besides the tests specified above, additional tests may be carried out at certain mileage gaps. Such gaps between the tests shall be approximately uniform.
	The total number of tests carried out, including the first and final test shall be at least 5.
	If the final test coincides with a scheduled maintenance, only the final test shall be carried out before the maintenance. In this case test after maintenance shall not be carried out.
8.2	The difference between the actual mileage accumulation at each test spot and the planned mileage accumulation shall not exceed 200km
8.3	Emission tests shall be carried out as per the procedure used for type approval testing as per document No. MoSRTH/CMVR/TAP115/116
8.4	During the emission test, if the test is affected by abnormal behavior of the vehicle, test shall be discarded. In any other case, the test result shall be deemed effective.

	The results which are discarded and the reasons thereof shall be recorded in the test report.
8.5	<p>If more than one test is carried out at each spot, the number of effective tests (see 9.1) at each spot shall be same. If so each spot result can be used for regression.</p> <p>If the number of effective tests at each spot is not the same, the average of results for each spot shall be used for final calculation.</p> <p>The number of effective tests for each spot shall not be more than three.</p>
8.6	If two vehicles of one model are selected to take durability test at the same time, the number of tests and mileage accumulation at each test spot shall be same for each vehicle.
9	Calculation of deterioration factor
9.1	The results of tests at all spots as per 8.1.1, 8.1.2, 8.1.3 and 8.1.4, excluding those discarded, as per para 8.4, are the effective test results and shall be considered for calculation of deterioration factor
9.2	Emission test result of any pollutant less than 0.01g/km, shall be deemed to be 0.01g/km.
9.3	The emission data before and after maintenance shall not be averaged.
9.4	The actual mileage number shall be rounded upto the last digit before decimal point, when expressed in kilometer.
9.5	The test result of each pollutant shall be corresponded to the mileage number. Using the least square method, regress out linear function, for each pollutant separately.
9.6	Use the linear function to calculate the pollutant value at 2500km and 80,000 kilometer. The value of the pollutant shall be calculated to the fourth digit after the decimal point, when expressed in g/km.
9.7	Divide the number at L km by the number at 2500km to work out the D.F. The D.F. shall be calculated to the third digit after the decimal point.
9.8	If D.F. is less than 1, it shall be deemed as 1.
9.9	D.F. for each applicable pollutant shall be calculated separately.
10	Extrapolation of the test results:
10.1	After accumulating at least half the specified kilometer 80,000 km, given in para 9.6, carry out regression of the results between 2500km and actual kilometre as per para 9.5.

11. The D.F. established as per this procedure (para 9 and 10) shall be applicable for all models of the same engine family

**Annex 1**

Table A1. Mode-wise break up for Laps 1 to 9 of Test cycle classification A

Mod	Driving Mode Lap speed--->	Time for each mode (second)		
		30	35	40
1	Acceleration: Idle - Lap speed	13	15	18
2	Steady state cruise	68	68	52
3	Deceleration: Lap speed - 15km/h	10	11	10
4	Acceleration: 15km/h - Lap speed	10	11	10
5	Steady state cruise	45	45	37
6	Deceleration: Lap speed - idle	10	11	10
7	Idle	15	15	15
8	Acceleration: Idle - Lap speed	13	15	18
9	Steady state cruise	100	100	85
10	Deceleration: Lap speed - 15km/h	10	11	10
11	Acceleration: 15km/h - Lap speed	10	11	10
12	Steady state cruise	100	100	85
13	Deceleration: Lap speed - 15km/h	10	11	10
14	Acceleration: 15km/h - Lap speed	10	11	10
15	Steady state cruise	52	33	29
16	Deceleration: Lap speed - idle	10	11	10
17	Idle	15	15	15
18	Acceleration: Idle - Lap speed	13	15	18
19	Steady state cruise	63	63	52
20	Deceleration: Lap speed - 15km/h	10	11	10
21	Acceleration: 15km/h - Lap speed	10	11	10
22	Steady state cruise	52	11	30
23	Deceleration: Lap speed - idle	10	11	10
24	Idle	15	15	15
25	Acceleration: Idle - Lap speed	13	15	18
26	Steady state cruise	52	52	30
27	Deceleration: Lap speed - 15km/h	10	11	10
28	Acceleration: 15km/h - Lap speed	10	11	10
29	Steady state cruise	59	50	44
30	Deceleration: Lap speed - idle	10	11	10

Table A2. Mode-wise break up for Lap 10 & 11 of Test cycle classification A

	Driving Mode	Time for each mode (second)
--	--------------	-----------------------------

	Mod	Lap speed--->	For Lap 10	For Lap 11
			40	40
	1	Acceleration: Idle - Lap speed	18	10
	2	Steady state cruise	515	260
	3	Deceleration: Lap speed - idle	18	18
	4	Idle	Not applicable	15
	5	Acceleration: Idle - Lap speed		10
	6	Steady state cruise		260
	7	Deceleration: Lap speed - idle		18



## Chapter 11

### DETAILS FOR STANDARDS FOR EVAPORATIVE EMISSION FROM QUADRICYCLE FITTED WITH SPARK-IGNITION ENGINES

#### Annexure 1:

TYPE-IV TEST: THE DETERMINATION OF EVAPORATIVE EMISSIONS FROM  
QUADRICYCLE WITH SPARK-IGNITION ENGINES

#### Annexure 2:

CALIBRATION OF EQUIPMENT FOR EVAPORATIVE  
EMISSION TESTING

## ANNEXURE 1

1	<b>INTRODUCTION:</b>
	This procedure describes a method for the determination of the loss of hydrocarbons by evaporation from the fuel systems of quadricycle vehicles While preparing this standard considerable assistance has been taken from
a)	California evaporative emission standards and test procedures for 2001 and subsequent model motor vehicles
b)	91/441/EEC Air pollution by emission from motor vehicles.
2	<b>DESCRIPTION OF TEST:</b>
	The evaporative emission Sealed Housing Evaporative Determination (SHED) test (Figure 1) consists of a conditioning phase and a test phase, as follows
a)	Conditioning Phase: <ul style="list-style-type: none"> <li>• Driving Cycle as per Type I test;</li> <li>• Vehicle Soak</li> </ul>
b)	Test Phase: <ul style="list-style-type: none"> <li>• Diurnal (breathing loss) test;</li> <li>• Driving Cycle as per Type I test;</li> <li>• Hot Soak loss test.</li> </ul>
	Mass emissions of hydrocarbons from the tank breathing loss and the hot soak loss phases are added together to provide an overall result for the test
3.0	<b>TEST VEHICLE AND TEST FUEL:</b>
3.1	<b>Test Vehicle</b>
3.1.1	The vehicle shall be in good mechanical condition and before the evaporative test, have been run in and driven at least 1000 km. The evaporative emission control system must be connected and functioning correctly over this period and the carbon canister and evaporative emission control valve subjected to normal use, neither undergoing abnormal purging nor abnormal loading.
3.2	<b>Test Fuel</b>
3.2.1	The reference fuel as applicable by gazette notification shall be used. If the engine is lubricated by a fuel oil mixture, the oil added to reference fuel shall comply as to grade and quantity with the manufacturer's recommendation during driving cycle
4.0	<b>TEST EQUIPMENT</b>
4.1	<b>Chassis dynamometer</b> The chassis dynamometer must meet the requirements of para 4 of Chapter 3 of Part-XIII, of this document
4.2	<b>Evaporative emission measurement enclosure.</b>
	<b>Evaporative emission measurement enclosure (SHED).</b> The evaporative emission measurement enclosure shall be a gas-tight rectangular measuring chamber able to contain the vehicle under test. The vehicle shall be accessible from all sides when inside and the enclosure when sealed must be gas tight in accordance with Annexure 2. The inner surface of the enclosure must be impermeable to hydrocarbons. At least one of the surfaces shall incorporate a flexible impermeable material or other device to allow the equilibration of pressure changes resulting from small changes in temperature. Wall design shall be such as to promote good dissipation of heat
4.3	<b>Analytical System</b>

4.3.1	Hydrocarbon analyser
4.3.1.1	The atmosphere within the chamber is monitored using a hydrocarbon detector of the flame ionisation detector (FID) type. Sample gas must be drawn from the midpoint of one sidewall or roof of the chamber and any bypass flow must be returned to the enclosure, preferably to a point immediately downstream of the mixing fan
4.3.1.2	The hydrocarbon analyser must have a response time to 90% of final reading of less than 1.5 seconds. Its stability shall be better than 2% of full scale at zero and at $80 \pm 20\%$ of full scale over a 15-minute period for all operational ranges.
4.3.1.3	The repeatability of the analyser expressed as one standard deviation shall be better than 1% of full-scale deflection at zero and at $80 \pm 20\%$ of full scale on all ranges used.
4.3.1.4	The operational ranges of the analyser must be chosen to give best resolution over the measurement, calibration and leak checking procedures
4.3.2	Hydrocarbon analyser data recording system
4.3.2.1	The hydrocarbon analyser must be fitted with a device to record electrical signal output either by strip chart recorder or other data-processing system at a frequency of at least once per minute. The recording system must have operating characteristics at least equivalent to the signal being recorded and must provide a permanent record of results. The record shall show a positive indication of the beginning and end of the fuel tank heating and hot soak periods together with the time elapsed between start and completion of each test.
4.4	<b>FUEL TANK HEATING SYSTEM</b>
4.4.1	1 The tank fuel heating system shall consist of two separate heat sources with two temperature controllers. A typical heat source is a pair of heating strips. Other sources may be used as required by the circumstances. At the request of manufacturer the test agency may allow manufacturer's to provide the heating apparatus for compliance testing. The temperature controllers may be manual, such as variable transformers, or they may be automated. Since vapor and fuel temperature are to be controlled separately, an automatic controller is recommended for both the fuel and vapour. The heating system shall not cause hot spots on the wetted surface of the tank, which could cause local over heating of the fuel. Heating strip for the fuel, if used, should be located as low as practicable on the Fuel tank and shall cover at least 10% of the wetted surface. The centerline of the fuel heating strip, if used, shall be below 30% of the fuel depth as measured from the bottom of the fuel tank and approximately parallel to the fuel level in the tank. The centerline of the vapor heating strips, if used, should be located at the approximate height of the center of vapor volume. The temperature controller must be capable of controlling the fuel and vapor temperatures to the heating function described in 5.3.8.
	<i>Note - In order to ensure uniform and appropriate heating and measurement of temperature for fuel and vapour the following precaution or the manufacturer recommendations shall be followed, such as :</i>
	<i>(a) No fuel heating pad shall be located above a 40% volume fill line from bottom. Likewise no vapour heating pad in an exposed tank evaporative test should be below the 60% volume fill line from bottom</i>

	<i>(b) Separate heating pads for fuel and vapour shall cover as much area as possible respectively</i>
	<i>c) The pasting of heating pads on either side of fuel tank shall be symmetric for fuel and vapour heating.</i>
	<i>(d) The position of fuel and vapour temperature sensors shall be as close to the area covered by heating pads respectively</i>
4.4.2	With temperature sensors positioned as in paragraph 4.5.2, the fuel heating device shall make it possible to evenly heat the fuel and vapor in the tank in accordance with heating function described in 5.3.8. The heating system shall be capable of controlling the fuel & vapor temperature to $\pm 1.7$ °K of the required temperature during the tank heating process
4.4.3	Notwithstanding the requirements of 4.4.2. if a manufacturer is unable to meet the heating requirement specified, for example due to use of thick-walled plastic fuel tanks, then the closest possible alternative heat slope shall be used. Prior to the commencement of any test, manufacturers shall submit engineering data to the testing agency to support the use of an alternative heat slope
4.5	<b>TEMPERATURE RECORDING</b>
4.5.1	The temperature in the chamber is recorded at two points by temperature sensors, which are connected so as to show a mean value. The measuring points are extended approximately 0.1m into the enclosure from the vertical centerline of each sidewall at a height of $0.9 \pm 0.2$ m.
4.5.2	The temperatures of the fuel and fuel vapor shall be recorded by means of the sensor positioned in the fuel tank as in section 5.1.1. When sensors cannot be positioned as specified in paragraph 5.1.1, such as where a fuel tank with two ostensibly separate chambers is used, sensors shall be located at the approximate mid-volume of each fuel or vapor containing chamber. In this case, the average of these temperature readings shall constitute the fuel and vapor temperatures
4.5.3	Throughout the evaporative emission measurements, temperature shall be recorded or entered in to a data processing system at a frequency of at least once per minute
4.5.4	The accuracy of the temperature recording system shall be within $\pm 1.7$ K and the temperature must be capable of being resolved to 0.5 K
4.5.5	The recording or data processing system must be capable of resolving time to $\pm 15$ seconds
4.6	<b>Fan</b>
4.6.1	It must be possible to reduce the hydrocarbon concentration in the chamber to the ambient hydrocarbon level by using one or more fans or blowers with the SHED door(s) open.
4.6.2	The chamber must have one or more fans or blowers of likely capacity 0.1 to 0.5 m <sup>3</sup> /s with which to thoroughly mix the atmosphere in the enclosure. It must be possible to attain an even temperature and hydrocarbon concentration in the chamber during measurements. The vehicle in the enclosure must not be subjected to a direct stream of air from the fans or blowers
4.7	<b>Gases</b>
4.7.1	The following pure gases must be available for calibration and operation
	a) Purified synthetic air (purity: < 1 ppm C1 equivalent < 1 ppm CO, < 400 ppm CO <sub>2</sub> , 0.1 ppm NO); oxygen content between 18 and 21% by volume

	b) Hydrocarbon analyzer fuel gas (40 ± 2% hydrogen, and balance helium with less than 1 ppm C1 equivalent hydrocarbon, less than 400 ppm CO <sub>2</sub> );
	c) Propane (C <sub>3</sub> H <sub>8</sub> ), 99.5% minimum p
4.7.2	Calibration and span gases shall be available containing mixtures of propane (C <sub>3</sub> H <sub>8</sub> ) and purified synthetic air. The true concentrations of a calibration gas must be within ± 2% of the stated figures. The accuracy of the diluted gases obtained when using a gas divider must be to within ± 2% of the true value. The concentrations specified in MOSRTH/CMVR/TAP-115/116, Issue 4 as amended time to time, may also be obtained by the use of a gas divider using synthetic air as the diluent gas
4.8	<b>Additional equipment</b>
4.8.1	The relative humidity in the test area must be measurable to within ± 5%
4.8.2	The pressure within the test area must measurable to within ± 0.1 kPa.
4.9	<b>Alternative Equipment</b>
4.9.1	At the request of the manufacturer, the testing agency may authorize the use of alternative equipment provided that it can be demonstrated that such equipment gives equivalent results.
5	<b>TEST PROCEDURE</b>
5.1	Test preparation
5.1.1	The vehicle is mechanically prepared before the test as follows:
	a) The exhaust system of the vehicle shall not exhibit any leaks;
	b) The vehicle may be steam - cleaned before the test;
	c) The fuel tank of the vehicle shall be equipped with temperature sensors so that the temperature of the fuel and fuel vapour in the fuel tank can be measured when it is filled to 50% ± 2% of its Manufacturer declared capacity. Sensors should be positioned as described in 4.5.2
	d) Additional fittings, adaptors or devices may optionally be fitted to allow a complete draining of the fuel tank. Alternatively, the fuel tank may be evacuated by means of a pump or siphon that prevents fuel spillage
5.1	<b>Conditioning Phase</b>
5.1.1	The vehicle shall be taken into the test area where the ambient temperature is between 293.2 K and 303.2 K (20°C and 30°C)
5.1.2	The ageing of the canister(s) has to be verified. This may be done by demonstrating that it has accumulated a minimum of 1000 km. If this demonstration is not given, the following procedure is used. In the case of a multiple canister system each canister must undergo the procedure separately
5.1.3	The canister is removed from the vehicle. Special care must be taken during this step to avoid damage to components and the integrity of the fuel system
5.1.4	The weight of the canister must be checked.
5.1.5	The canister is connected to a fuel tank, possibly an external one, filled with reference fuel, to 50% volume of the fuel tank(s).
5.1.6	The fuel temperature in the fuel tank must be between 283 K (10 °C) and 287 K (14 °C)
5.1.7	The (external) fuel tank is heated from 288 K to 318 K (15 °C to 45 °C) (1 °C increase every 9 minutes)
5.1.8	If the canister reaches breakthrough before the temperature reaches 318 K (45°C), the heat source must be turned off. Then the canister is weighed. If the

	canister did not reach breakthrough during the heating to 318 K (45 °C), the procedure from 5.2.5 must be repeated until breakthrough occurs.
5.1.9	Breakthrough may be checked as is described in 5.2 and 5.3 of this Chapter, or with the use of another sampling and analytical arrangement capable of detecting the emission of hydrocarbons from the canister at breakthrough
5.1.10	The canister must be purged with 25 ± 5 liters per minute with the emission laboratory air until 300 bed volume exchanges are reached
5.1.11	The weight of the canister must be checked
5.1.12	The steps of the procedure in 5.1.6 and 5.1.11 must be repeated nine times. The test may be terminated prior to that, after not less than three ageing cycles, if the weight of the canister after the last cycles has stabilized.
5.1.13	The evaporative emission canister is reconnected and the vehicle restored to its normal operating condition.
5.1.14	One of the methods specified in 5.2 and 5.3 must be used to precondition the evaporative canister. For vehicles with multiple canisters, each canister must be preconditioned separately
5.1.15	Canister emissions are measured to determine breakthrough.
5.1.16	Breakthrough is here defined as the point at which the cumulative quantity of hydrocarbons emitted is equal to 2 grams
5.1.17	Breakthrough may be verified using the evaporative emission enclosure as described in 5.2 and 5.3 respectively. Alternatively, breakthrough may be determined using an auxiliary evaporative canister connected downstream of the vehicle's canister. The auxiliary canister must be well purged with dry air prior to loading
5.1.18	The measuring chamber must be purged for several minutes immediately before the test until a stable background is obtained. The chamber air mixing fan(s) must be switched on at this time. The hydrocarbon analyzer must be zeroed and spanned immediately before the test
5.2	<b>Canister Loading with Repeated Heat Builds to Breakthrough</b>
5.2.1	The fuel tank(s) of the vehicle(s) is (are) emptied using the fuel tank drain(s). This must be done so as not to abnormally purge or abnormally load the evaporative control devices fitted to the vehicle. Removal of the fuel cap is normally sufficient to achieve this.
5.2.2	The fuel tank(s) is (are) refilled with test fuel at a temperature of between 283 K to 287 K (10 to 14 °C) to 50% ± 2 % of the tank's normal volumetric capacity. The fuel cap(s) of the vehicle must be fitted at this point
5.2.3	Within one hour of being refueled the vehicle must be placed, with the engine shut off, in the evaporative emission enclosure. The fuel tank temperature sensor is connected to the temperature recording system. A heat source must be properly positioned with respect to the fuel tank(s) and connected to the temperature controller. The heat source is specified in 4.4 In the case of vehicles fitted with more than one fuel tank, all the tanks must be heated in the same way as described below. The temperatures of the tanks must be identical to within ± 1.5 °K.
5.2.4	fuel may be artificially heated to the starting diurnal temperature of 293 K (20 °C) ± 1 K
5.2.5	When the fuel temperature reaches at least 292 K (19 °C), the following steps must be taken immediately; the purge blower must be turned off; enclosure doors

	closed and sealed; and measurement initiated of the hydrocarbon level in the enclosure
5.2.6	When the fuel temperature of the fuel tank reaches 293 K (20 °C) a linear heat build of 15 K (15 °C) begins. The fuel must be heated in such a way that the temperature of the fuel during the heating conforms to the function below to within $\pm 1.5$ °K. The elapsed time of the heat build and temperature rise is recorded
	$T_r = T_0 + 0.2333 \times T$ Where: $T_r$ = required temperature (K); $T_0$ = initial temperature (K); $T$ = time from start of the tank heat build in minutes
5.2.7	As soon as breakthrough occurs or when the fuel temperature reaches 308 °K (35 °C), whichever occurs first, the heat source is turned off, the enclosure doors unsealed and opened, the vehicle fuel tank cap(s) removed. If breakthrough has not occurred by the time the fuel temperature reaches 308 °K (35 °C), the heat source is removed from the vehicle, the vehicle removed from the evaporative emission enclosure and the entire procedure repeated until breakthrough occurs.
5.3	<b>Butane Loading to Breakthrough</b>
5.3.1	If the enclosure is used for the determination of the breakthrough (see 5.2.17) the vehicle must be placed, with the engine shut off, in the evaporative emission enclosure
5.3.2	The evaporative emission canister must be prepared for the canister loading operation. The canister must not be removed from the vehicle, unless access to it in its normal location is so restricted that loading can only reasonably be accomplished by removing the canister from the vehicle. Special care must be taken during this step to avoid damage to the components and the integrity of the fuel system
5.3.3	The canister is loaded with a mixture composed of 50% butane and 50% nitrogen by volume at a rate of 15 grams butane per hour
5.3.4	As soon as the canister reaches breakthrough, the vapor source must be shut off
5.3.5	The evaporative emission canister must then be reconnected and the vehicle restored to its normal operating condition
5.4	The fuel tank(s) shall be drained through the provided fuel tank(s) drain(s) and charged with the specified test fuel to half of the tank capacity\
5.5	The vehicle is placed on a chassis dynamometer and is driven through the driving test cycle specified in notification. Exhaust emissions may be sampled during this operation but the results are not used [for the purpose of exhaust emission type approval]
5.6	The vehicle is parked in the test area for the minimum period 6- 36 hrs.
5.8	<b>TANK BREATHING (DIURNAL) EVAPORATIVE EMISSION TESTS</b>
5.8.1	The measuring chamber shall be vented / purged for several minutes immediately before the test until a stable background is obtainable. The chamber mixing fan (s) must be switched on at this time also.
5.8.2	The hydrocarbon analyser must be zeroed and spanned immediately before the test
5.8.3	The fuel tank(s) shall be emptied as described in paragraph 5.1.1 and refilled with test fuel at a temperature of between 283.2K and 287.2 K (10°C and 14°C) to $50 \pm 2\%$ of its Manufacturer declared capacity-and with the motorcycle resting on its center stand (or a similar support) in the vertical position

	The fuel cap (s) of the vehicle must not be fitted at this point
5.8.4	In the case of vehicles fitted with more than one fuel tank, all the tanks shall be heated in the same way, as described below. The temperatures of the tanks must be identical to within $\pm 1.5$ °K
5.8.5	The test vehicle shall be brought into the test enclosure with the engine switched off, parked in an upright position and fuel tank shut of valve if manual, shall be put in off position as instructed in user's manual. The fuel tank sensors and the fuel tank heating device, if necessary, shall be connected. Immediately begin recording the fuel temperature and the air temperature within the enclosure. If a venting/purging fan is still operating, it shall be switched off at this time
5.8.6	The fuel and vapor may be artificially heated to the starting temperature of 288.7 K (15.5°C) $\pm 1$ K and 294.2 K (21.0°C) $\pm 1$ K respectively
5.8.7	As soon as the fuel temperature reaches 287.2 K (14.0 °C) and the vapour temperature reaches 292.7 K (19.5 °C), the cap of the fuel tank(s) shall be sealed and the chamber shall be sealed so that it is gas-tight
5.8.8	As soon as the fuel reaches a temperature of 288.7K (15.5°C) $\pm 1$ K and the vapour temperature 294.2 K (21°C) 2 the test procedure shall continue as follows
	a) The hydrocarbon concentration, barometric pressure and the temperature shall be measured to give the initial readings CHCi, i, Pi and Ti for the tank heat build test
	b) A linear heat build of 13.3 K or 20 $\pm 0.5$ K over a period of 60 $\pm 2$ minutes shall begin. The temperature of the fuel and fuel vapour during the heating shall conform to the function below to within $\pm 1.7$ K, or the closest possible function as described in 4.4.3
	Tf = (0.3333)* t + 288.7 K Tv = (0.3333)* t + 294.2 K where: Tf = required temperature of fuel (K); Tv = required temperature of vapour (K); t = time from start of the tank heat build in minutes.
5.8.81	The test duration shall be 60 $\pm 2$ minutes, giving a fuel and vapour temperature rise of 20 K or 13.3 K. The final fuel temperature shall be 308.5 K $\pm 0.5$ K or 301.3 $\pm 0.5$ K.
5.8.8.2	An initial vapor temperature up to 5°C above 21°C may be used. For this condition, the vapor shall not be heated at the beginning of the diurnal test. When the fuel temperature has been raised to 5.5°C below the vapor temperature by following the Tf function, the remainder of the vapor heating profile shall be followed
5.8.9	The hydrocarbon analyser is zeroed and spanned immediately before the end of the test
5.8.10	If the heating requirements in paragraph 5.8.8 have been met over the 60 $\pm 2$ minute period of the test, the final hydrocarbon concentration in the enclosure is measured (CHCf). The time or elapsed time of this is recorded, together with the final temperature and barometric pressure Tf and pf
5.8.11	The heat source is turned off and the enclosure door unsealed and opened. The heating device and temperature sensor are disconnected from the enclosure apparatus. The vehicle is now removed from the enclosure with the engine switched off.



5.8.12	The vehicle is prepared for the subsequent driving cycle and hot soak evaporative emission test. The cold start test must follow the tank breathing test by a period of not more than one hour
5.8.13	The driving cycle shall begin within 60 minutes of the completion of the breathing loss test
5.9	<b>Driving Cycle</b>
5.9.1	Following the tank breathing losses test, the vehicle is pushed or otherwise maneuvered onto the chassis dynamometer with the engine switched off. It is then driven through the Type I test cycle .At the request of the manufacturer, exhaust emissions may be sampled during this operation, but the results are not used {for the purpose of exhaust emission type – approval
5.10	<b>HOT SOAK EVAPORATIVE EMISSIONS TEST</b>
5.10.1	The determination for evaporative emissions is concluded with the measurement of hydrocarbon emissions over a 60-minute hot soak period. The hot soak test shall begin within seven minutes of the completion of the driving cycle specified in paragraph 5.9.1
	Before the completion of the driving cycle run, the measuring chamber must be purged for several minutes until a stable hydrocarbon background is obtained. The enclosure mixing fan(s) must also be turned on at this time
	The hydrocarbon analyser must be zeroed and spanned immediately prior to the test.
5.10.3	The vehicle shall be pushed or otherwise moved into the measuring chamber with the engine switched off and fuel tank shut of valve if manual be put in off position
5.10.4	The enclosure doors are closed and sealed gas-tight within seven minutes of the end of the driving cycle
5.10.5	The start of $60 \pm 0.5$ minute hot soak period begins when the chamber is sealed
	The hydrocarbon concentration, temperature and barometric pressure are measured to give the initial readings $CHC_i$ , $P_i$ and $T_i$ for the hot soak test. These figures are used in the evaporative emission calculation, clause 6. The ambient SHED temperature $T$ must not be less than 293.2 K and not more than 303.2 K during the 60 minute hot soak period
	The hydrocarbon analyser must be zeroed and spanned immediately before the end of the $60 \pm 0.5$ minute test period.
5.10.7	At the end of the $60 \pm 0.5$ minute test period measure the hydrocarbon concentration in the chamber.The temperature and the barometric pressure are also measured. These are the final readings $CHC_f$ , $P_f$ and $T_f$ for the hot soak test used for the calculation in clause 6. This completes the evaporative emission test procedure.
5.11	<b>Alternative test procedures :</b>
5.11.1	At the request of the manufacturer alternative methods may be used to demonstrate compliance with the requirements of this annex. In such cases, the manufacturer shall satisfy the test agency that the results from the alternative test can be correlated with those resulting from the procedure described in this annex. This correlation shall be documented and included in the test report
6.0	<b>CALCULATION OF RESULTS :</b>

6.1	<p>The evaporative emission tests described in clause 5 allow the hydrocarbon emissions from the tank breathing and hot soak phases to be calculated. Evaporative losses from each of these phases are calculated using the initial and final hydrocarbon concentrations, temperatures and pressures in the enclosure, together with the net enclosure volume</p>
	<p>The formula below is used:</p> $MHC = k * V * 10^{-4} [CHC_f * P_f / T_f - CHC_i * P_i / T_i]$ <p>Where:  MHC= mass of hydrocarbon emitted over the test phase (grams).  CHC = measured hydrocarbon concentration in the enclosure (ppm (volume) C equivalent).  V = net enclosure volume in cubic meters corrected for the volume of the vehicle, If the volume of the vehicle is not determined a volume of 0.25 m<sup>3</sup> is subtracted  T = ambient chamber temperature, K. P = barometric pressure in kPa  H/C = hydrogen to carbon ratio. <math>k = 1.2(12 + H/C)</math>:</p> <p>Where: i is the initial reading  f is the final reading.  H/C is taken to be 2.33 for tank breathing losses.  H/C is taken to be 2.20 for hot soak losses.</p>
6.2	<p><b>Overall results of test</b></p>
	<p>The overall hydrocarbon mass emission for the vehicle is taken to be: <math>M_{total} = M_{TH} + M_{HS}</math></p> <p><math>M_{total}</math> = overall evaporative mass emissions of the vehicle (grams).  <math>M_{TH}</math> = Evaporative hydrocarbon mass emission for the tank heatbuild (grams).  <math>M_{HS}</math> = Evaporative hydrocarbon mass emission for the hot soak (grams)</p> <p>Note: Tailpipe emissions may be measured during dynamometer test, but these are not used for certification</p>

**Steam clean of vehicle (if necessary)**

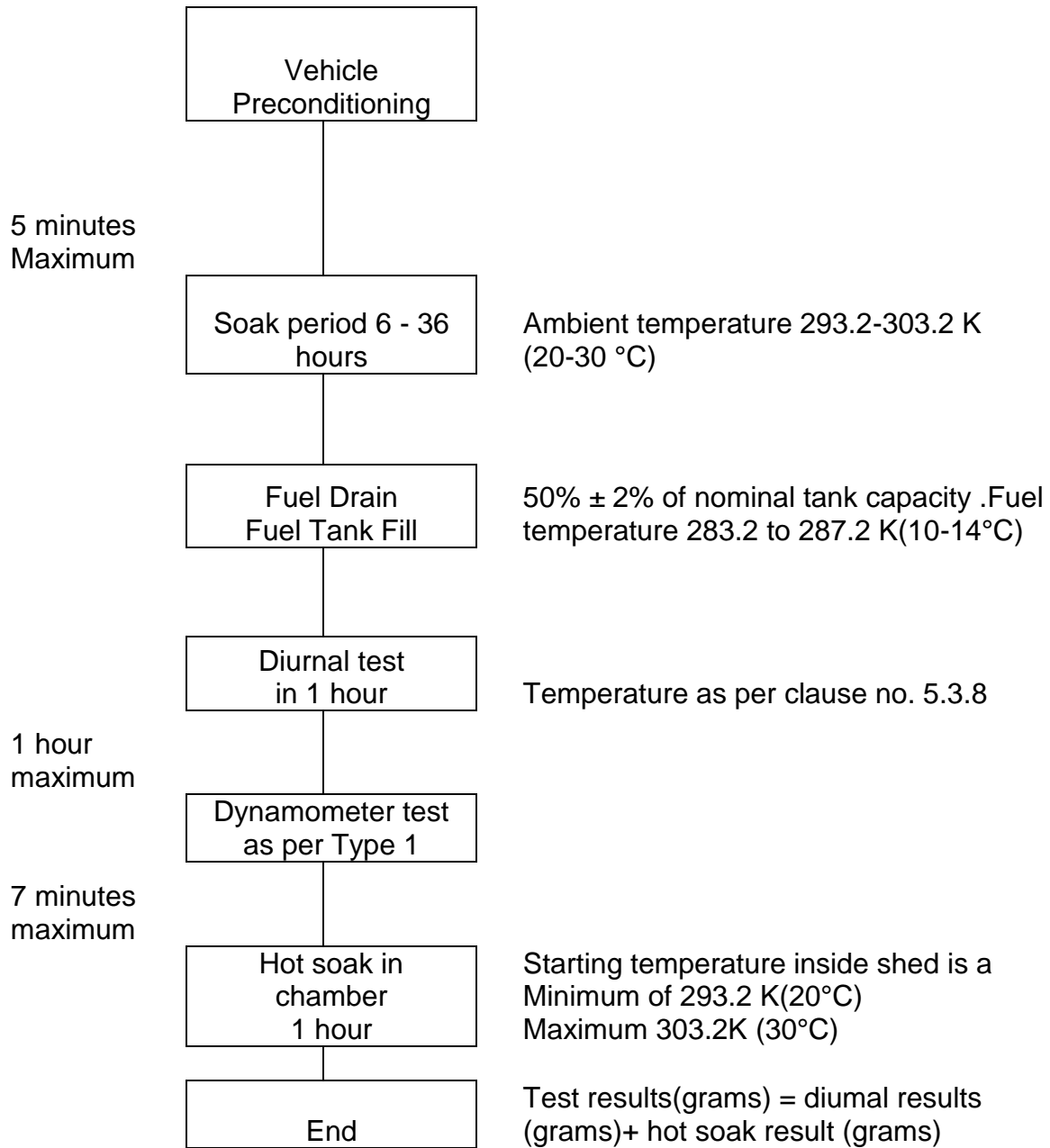

**FIG 1 - EVAPORATIVE EMISSION DETERMINATION SHED TEST**

7.0	<b>CONFORMITY OF PRODUCTION ( for vehicles with Evaporative control system)</b>
7.1	For routine end of production-line testing, the holder of the approval may demonstrate compliance by sampling vehicles which shall meet the following requirements. Alternatively, the full test procedure described in this Annex shall be carried out. At the request of the manufacturer an alternative test procedure may be used, if the procedure has been presented to and has been accepted during the type approval procedure by the test agency.

7.2	Test for leakage:
7.2.1	Vents to the atmosphere from the evaporative emission control system shall be isolated.
7.2.2	A pressure of 370±10mm of H <sub>2</sub> O shall be applied to the fuel system
7.2.3	The pressure must be allowed to stabilize prior to isolating the fuel system from the pressure source
7.2.4	Following isolation of the fuel system,the pressure shall not drop by more than 50 mm of H <sub>2</sub> O in five minutes
7.3	Tests for Venting
7.3.1	Vents to the atmosphere from the emission control shall be isolated
7.3.2	A pressure of 370±10mm of H <sub>2</sub> O shall be applied to the fuel system.
7.3.3	The pressure shall be allowed to stabilize prior to isolating the fuel system from the present source
7.3.4	The venting outlets from the emission control systems to the atmosphere shall be reinstated to the production condition
7.3.5	The pressure of the fuelsystem shall drop to below 100mm of H <sub>2</sub> O within two minutes
7.4	PurgeTest:
7.4.1	Equipment capable of detecting an air flow rate of 0.25 litres in one minutes shall be attached to the purge inlet and a pressure vessel of sufficient size to have negligible effecton the purge system shall be connected via a switching valve to the purgeinlet,oralternatively
7.4.2	The manufacturer may use aflowmeter of his own choice,if acceptable to the competent authority
7.4.3	The vehicle shall be operated in such a manner that any design features of the purge system that could restrict purge operation is detected and the circumstances noted.
7.4.4	Whilstthe engine is operating within the bounds note in 8.4.3 the air flow shall be determined by either
7.4.4.1	The device being switched in a pressure drop from atmosphere to a level indicating that a volume of 0.25 litres of air has flowed into the evaporative emission control system within one minute or
7.4.4.2	The device being switched in a pressure drop from atmosphere to a level indicating that a volume of 0.25 litres of air has flowed into the evaporative emission control system within one minute or
7.5	If the requirements of 7.2, 7.3and 7.4 are not met the competent authority must ensure that all necessary steps are taken tor establish conformity of production as rapidly as possible byconducting a test as per this part

## Annexure 2

1	<b>CALIBRATION FREQUENCY AND METHODS</b>
1.1	All equipment must be calibrated before its initial use and then calibrated as often as necessary and in any case in the month before type-approval testing. The calibration methods to be used are described in this Annexure
2	<b>CALIBRATION OF THE ENCLOSURE</b>
2.1	<b>Initial determination of enclosure internal volume</b>
2.1.1	Before its initial use, the internal volume of the chamber must be determined as follows. The internal dimensions of the chamber are carefully measured, allowing for any irregularities such as bracing struts. The internal volume of the chamber is determined from these measurements
2.1.2	The net internal volume is determined by subtracting 0.25 m <sup>3</sup> from the internal volume of the chamber. Alternatively the actual volume of the vehicle of the test vehicle may be subtracted
2.1.3	The chamber shall be checked as in item 2.3. If the propane mass does not tally to within $\pm 2\%$ with the injected mass, then corrective action is required.
2.2	<b>Determination of chamber background emissions</b>
	This operation determines that the chamber does not contain any materials that emit significant amounts of hydrocarbons. The check must be carried out at the enclosure's introduction to service, after any operation in the enclosure which may affect background emissions and at a frequency of at least once per year.
2.2.1	Calibrate the analyser (if required), The Hydrocarbon analyser shall be zeroed and spanned immediately, before the test.
2.2.2	Purge the enclosure until a stable hydrocarbon reading is obtained. The mixing fan is turned on if not already on. The hydrocarbon analyzer must be zeroed and spanned immediately before the end of the test
2.2.3	Seal the chamber and measure the background hydrocarbon concentration, temperature and barometric pressure. These are the initial readings C H <sub>ci</sub> , P <sub>i</sub> and T <sub>i</sub> used in the enclosure background calculation
2.2.4	The enclosure is allowed to stand undisturbed with the mixing fan on for a period of four hours
2.2.5	At the end of this time use the same analyser to measure the hydrocarbon concentration in the chamber. The temperature and the barometric pressure are also measured. These are the final readings C H <sub>cf</sub> , P <sub>f</sub> and T <sub>f</sub> . The hydrocarbon analyzer must be zeroed and spanned immediately before the end of the test
2.2.6	Calculate the change in mass of hydrocarbons in the enclosure over the time of the test according to section 2.4 the background emission of the enclosure must not exceed 0.4 g.
2.3	<b>Calibration and hydrocarbon retention test of the chamber</b> The calibration and hydrocarbon retention test in the chamber provides a check on the calculated volume in 2.1 and also measures any leak rate

2.3.1	Purge the enclosure until a stable hydrocarbon concentration is reached. Turn on the mixing fan, if not already switched on. The hydrocarbon analyser is zeroed, calibration if required, and spanned
2.3.2	Seal the enclosure and measure the background concentration, temperature and barometric pressure. These are the initial readings $C_{Hci}$ , $P_i$ and $T_i$ used in the enclosure calibration
2.3.3	Inject a quantity of approximately 4 grams of propane into the enclosure. The mass of propane must be measured to an accuracy and precision of $\pm 2.0\%$ of the measured value.
2.3.4	Allow the contents of the chamber to mix for five minutes. The hydrocarbon analyzer must be zeroed and spanned immediately before the following test and then measure the hydrocarbon concentration, temperature and barometric pressure. These are the final readings $C_{HCf}$ , $P_f$ and $T_f$ for the calibration of the enclosure
2.3.5	Using the readings taken in 2.3.2 and 2.3.4 and the formula in 2.4, calculate the mass of propane in the enclosure. This must be within $\pm 2\%$ of the mass of propane measured in 2.3.3.
2.3.6	Allow the contents of the chamber to mix for a minimum of four hours. At the end of this period measure and record the final hydrocarbon concentration, temperature and barometric pressure. The hydrocarbon analyzer must be zeroed and spanned immediately before the end of the test
2.3.7	Calculate using the formula in 2.4, the hydrocarbon mass from the readings taken in 2.3.6 and 2.3.2. The mass may not differ by more than 4% from the hydrocarbon mass given by 2.3.5.
2.4	<b>Calculation</b> The calculation of net hydrocarbon mass change within the enclosure is used to determine the chamber's hydrocarbon background and leak rate. Initial and final readings of hydrocarbons concentration, temperature and barometric pressure are used in the following formula to calculate the mass change.
	$MHC = k * V * 10^{-4} [ CHC_f * P_f / T_f - CHC_i * P_i / T_i ]$ <p>where:</p> <p>MHC = hydrocarbon mass in grams.</p> <p>CHC = hydrocarbon in the enclosure (ppm Carbon (NB: ppm carbon = ppm propane *3)),</p> <p>V = net enclosure volume in cubic metres.</p> <p>T = ambient temperature in the enclosure, K. P = barometric pressure in kPa.</p> <p>k = 17.6</p> <p>When: i is the initial reading. f is the final reading.</p>
3	<b>CHECKING OF FID HYDROCARBON ANALYSER</b>

3.1	<p><b>Detector response optimization</b></p> <p>The FID must be adjusted as specified by the instrument manufacturer. Propane in air should be used to optimize the response on the most common operating range.</p>
3.2	<p><b>Calibration of the HC analyser</b></p> <p>The analyser should be calibrated using propane in air and purified synthetic air. 4.5.2 of, Chapter 3 of this part (Calibration and span gases). Establish a calibration curve as described in sections 4.1 to 4.5 below</p>
3.3	<p><b>Oxygen interference check and recommended limits:</b></p> <p>The response factor (R ) for a particular hydrocarbon species f in the ratio of the FID C reading to the gas cylinder concentration, expressed as ppm C . The concentration of the test gas must be at a level to give a response of approximately 80% of full scale deflection, for the operating range. The concentration must be known, to an accuracy of <math>\pm 2\%</math> in reference to a gravimetric standard expressed in volume. In addition the gas cylinder must be preconditioned for 24 hours at a temperature between 293 K and 303 K (20° and 30°C). Response factors should be determined when introducing an analyser into service and thereafter at major service intervals. The reference gas to be used is propane with balance purified air which is taken to give a response factor of 1.00</p>
	<p>The test gas to be used for oxygen interference and the recommended response factor range are given below Propane and nitrogen <math>0.95 \leq R_f \leq 1.05</math></p>
4	<p><b>CALIBRATION OF THE HYDROCARBON ANALYSER</b></p> <p>Each of the normally used operating ranges are calibrated by the following procedure</p>
4.1	<p>Establish the calibration curve by at least five calibration points spaced at evenly as possible over the operating range. The nominal concentration of the calibration gas with the highest concentration to be at least 80% of the full scale</p>
4.2	<p>Calculate the calibration curve by the method of least squares. If the resulting polynomial degree is greater than 3 then the number of calibration points must be at least the number of the polynomial degree plus 2.</p>
4.3	<p>The calibration curve must not differ by more than 2% from the nominal value of each calibration gas.</p>
4.4	<p>Using the coefficients of the polynomial derived from 4.2, a table of indicated reading against true concentration shall be drawn up in steps of no grater than 1% of full scale. This is to be carried out for each analyser range calibrated. The table shall also contain other relevant data such as</p>
	<p>Date of calibration, span and zero potentiometer readings (where applicable)</p> <p>Nominal scale Reference data of each calibration gas used.</p> <p>The actual and indicated value of each calibration gas used together with the percentage differences. FID fuel and type, FID air pressure</p>

4.5	If it can be shown to the satisfaction of the Regulatory Agency that alternative technology (e.g. computer, electronically controlled range switch) can give equivalent accuracy, then those alternatives may be used
-----	---



## Chapter 12

### TEST PROCEDURE FOR ON BOARD DIAGNOSTICS – I (OBD-I)

1.	INTRODUCTION
	This chapter applies to the Type Approval procedure for on-board diagnostic I (OBD I) system for the motor vehicles.
2.	DEFINITIONS
2.1	<b>'OBD I'</b> means an on-board diagnostic system for emission control, which shall have the capability of identifying the likely area of malfunction by means of fault codes stored in computer memory as specified in section 5.1 below of this chapter. For all subsequent references in this chapter OBD implies OBD I
2.2	<b>'Vehicle type'</b> means a category of power-driven vehicles, which do not differ in such essential engine and OBD system characteristics.
2.3	<b>'Vehicle family'</b> means a manufacturer's grouping of vehicles, which through their design, are expected to have similar exhaust emission and OBD system characteristics. Each vehicle of family shall have complied with the requirement of this document as defined in Annexure III to this Chapter
2.4	<b>'Emission control system'</b> means the electronic engine management controller and any emission-related component in the exhaust system, which supplies an input to or receives an output from this controller.
2.5	<b>'Malfunction indicator (MI)'</b> means a visible or audible indicator that clearly informs the driver of the vehicle in the event of a malfunction of any emissionrelated component connected to the OBD system, or the OBD system itself.
2.6	<b>'Circuit discontinuity' (CD)</b> means disconnection of only those components (sensors/actuators) which are monitored by EMS/ECU/Computer, by physically removing corresponding connector or cutting / separating wire(s) of corresponding sensor or actuator.
2.7	<b>'A driving cycle'</b> consists of engine start-up, driving mode where a malfunction would be detected if present, and engine shut-off.
3	APPLICATION FOR TYPE APPROVAL
3.1	The application for type approval of a vehicle model with regard to OBD of the vehicles shall be submitted by the vehicle manufacturer along with duly filled

	OBD specification sheet (refer annexure 1 for format) for components monitored by EMS/ECU/Computer & OBD flow chart application table (refer annexure 2 for format).
3.2	A vehicle representative of the vehicle model to be type approved shall be submitted to the test agency responsible for conducting tests for compliance to the requirements referred in Para 5 of this chapter.
<b>4.</b>	<b>TYPE APPROVAL</b>
	For the purpose of type approval, manufacturer can choose one of the below mentioned options (4.1 or 4.2)
4.1	The vehicle submitted for type approval shall be tested for maximum four discontinuity demonstration tests selected by the test agency out of the OBD parameters as declared by the vehicle manufacturer, subject to condition mentioned in clause 4.3.
4.2	Alternatively, the vehicle can be tested for all OBD parameters for discontinuity demonstration tests, subject to condition mentioned in clause 4.3.
4.3	If discontinuity demonstration test is conducted on any vehicle model for a particular OBD parameter, demonstration test for such OBD parameter need not be conducted once again in the new vehicle model of same vehicle family submitted for type approval. In this case the vehicle manufacturer has to fill the vehicle model in which the demonstration test was carried out and date of testing (in DEMO column of annex 2).
4.4	If the submitted vehicle meets the requirements of Para 5 below when tested as per the procedure described in Para 6 below for circuit discontinuity of parameters in Table in 5.1, approval of that vehicle model shall be granted.
<b>5.</b>	<b>REQUIREMENTS</b>
5.1	Vehicle submitted for type approval shall contain the OBD monitoring system. Please refer notification for OBD – I monitoring system.
5.2	The vehicle manufacturer shall submit a test vehicle along with necessary equipments, which can simulate the discontinuity of OBD - I parameters as declared by the manufacturer for testing.
<b>5.3</b>	<b>Activation of malfunction indicator (MI).</b>
5.3.4	Distance traveled since MIL is 'ON' shall be recorded.

5.3.5	The OBD system shall incorporate a malfunction indicator readily perceivable to the vehicle operator. The MI must not be used for any other purpose except to indicate emergency start-up or limp-home routines to the driver. The MI shall be visible in all reasonable lighting conditions. When activated, it shall display a symbol in conformity with ISO 2575. A vehicle shall not be equipped with more than one general purpose MI for emission-related problems. Separate specific purpose telltales (e.g. brake system, fasten seat belt, oil pressure, etc.) are permitted. The use of red color for an MI is prohibited.
5.3.6	The MI shall activate when the vehicle's ignition is in the "key-on" position before engine starting or cranking and de-activate before engine starting after few seconds (or 'on' till engine is started) if no malfunction has previously been detected.
5.3.7	For meeting the requirements of 5.1, the manufacturer shall take appropriate steps to demonstrate that the OBD system will indicate a fault when discontinuity occurs.
5.4	The OBD system shall be capable of recording the fault code(s) indicating the status of the emission control system.
5.4.1	The distance traveled by the vehicle while the MI is activated must be available at any instant through the serial port on the standard link connector. By means of derogation for vehicles equipped with a mechanically operating odometer that does not allow input to the electronic control unit, 'distance travelled' may be replaced with 'engine operation time' and shall be made available at any moment through the serial port on the standardised diagnostic connector (standardise link connector)
<b>6.</b>	<b>TEST PROCEDURE</b>
6.1	The test Vehicle shall be mounted on the chassis dynamometer along with necessary equipments of test agency for carrying out test ( OBD generic Scan tool and related accessories need to be provided by manufacturer)
6.2	Initial check
6.2.1	Switch "ON" the ignition and check for MIL "ON". MIL shall be "ON" for few seconds and then may turn "OFF" (in case of vehicle models with such design of MIL operation) or may continue to glow.
6.2.2	Start the engine and check for MIL "OFF".
6.2.3	Switch "OFF" the engine and ignition key to "OFF" position.
6.3	Circuit Discontinuity check

6.3.1	Vehicle soaking for 6 hours, if necessary for certain OBD parameters as specified by vehicle manufacturer.
6.3.2	Open or disconnect the circuit for the OBD parameter to be checked for circuit discontinuity.
6.3.3	Switch "ON" the ignition. Check for MIL "ON"
6.3.4	Start the engine and check for MIL "ON".
6.3.4.1	If the OBD parameter requires engine to be driven for MIL activation, vehicle shall be driven as per driving cycle (Type I test cycle); including key `ON` `OFF` cycles, vehicle can be considered meeting circuit discontinuity when the MIL activates within maximum of 10 driving cycles.
6.3.4.2	If the OBD parameter does not require vehicle to be driven for MIL activation, vehicle can be considered meeting circuit discontinuity for the tested OBD parameter.
6.3.4.3	The DTC code shall be retrieved by the OBD generic Scan tool or any other method as mutually agreed between test agency and vehicle manufacturer.
6.3.5	Procedure from 6.3.1 to 6.3.4 shall be repeated for other OBD parameters to be checked for circuit discontinuity.
6.4	The requirement of distance traveled or engine operating time since MIL "ON" shall be checked along with one of the circuit discontinuity tests for OBD parameters as specified by vehicle manufacturer by running the vehicle on chassis dynamometer or on road as per driving cycle preferred by the vehicle manufacturer.
6.5	The process flow is shown in the figure 1 of this chapter.
6.6	Diagnostic signals
6.6.1	Vehicles entering into service, the software calibration identification number shall be made available through the serial port on the standardised data link connector. The software calibration identification number shall be provided in a standardised format.
6.6.2	The emission control diagnostic system is not required to evaluate components during malfunction if such evaluation would result in a risk to safety or component failure.
6.6.3	The emission control diagnostic system must provide for standardised and unrestricted access and conform with the following ISO standards and/or SAE specification.
6.6.3.1	One of the following standards with the restrictions as described must be used as the on-board to off-board communications link:

	<p>ISO 9141 - 2: 1994 (amended 1996) "Road Vehicles - Diagnostic Systems - Part 2: CARB requirements for interchange of digital information";          SAE J1850: March 1998 "Class B Data Communication Network Interface".          Emission-related messages must use the cyclic redundancy check and the three byte header and not use interbyte separation or check sums;          ISO 14230 - Part 4 "Road Vehicles - Keyword protocol 2000 for diagnostic systems - Part 4: Requirements for emissions-related systems";          ISO DIS 15765-4 "Road vehicles - Diagnostics on Controller Area Network (CAN) - Part 4: Requirements for emissions-related systems", dated 1 November 2001.</p>
6.6.3.2	<p>Basic diagnostic data, (as specified in 6.5.1) and bi-directional control information must be provided using the format and units described in ISO DIS 15031-5 "Road vehicles - Communication between vehicle and external test equipment for emissions-related diagnostics - Part 5: Emissions-related diagnostic services", dated 1 November 2001, and must be available using a diagnostic tool meeting the requirements of ISO DIS 15031-4.          The vehicle manufacturer shall provide to a national standardisation body the details of any emission-related diagnostic data, e.g. PID's, OBD monitor Id's, Test Id's not specified in ISO DIS 15031-5 but related to TAP 115 / 116.</p>
6.6.3.3	<p>When a fault is registered, the manufacturer must identify the fault using an appropriate fault code consistent with those given in Section 6.3. of ISO DIS 15031-6 "Road vehicles - Communication between vehicle and external test equipment for emissions-related diagnostics - Part 6: Diagnostic trouble code definitions", relating to "emission related system diagnostic trouble codes". If such identification is not possible, the manufacturer may use diagnostic trouble codes according to Sections 5.3 and 5.6 of ISO DIS 15031-6. The fault codes must be fully accessible by standardised diagnostic equipment complying with the provisions of section 6.5.3.2.          The vehicle manufacturer shall provide to a national standardisation body the details of any emission-related diagnostic data, e.g. PID's, OBD monitor Id's, Test Id's not specified in ISO DIS 15031-5 but related to TAP 115 / 116.</p>
6.6.3.4	<p>The connection interface between the vehicle and the diagnostic tester must be standardized and must meet all the requirements of ISO DIS 15031-3 "Road vehicles – Communication between vehicle and external test equipment for emissions-related diagnostics - Part 3: Diagnostic connector and related electrical circuits: specification and use", dated 1 November 2001. The installation position must be subject to agreement of the approval authority such that it is readily accessible by service personnel but protected from accidental damage during normal conditions of use.</p>
6.6.3.5	<p>The manufacturer shall also make accessible, where appropriate on payment, the technical information required for the repair or maintenance of motor vehicles unless that information is covered by an intellectual property right or constitutes essential, secret know how which is identified</p>

	<p>in an appropriate form; in such case, the necessary technical information shall not be withheld improperly.</p> <p>Entitled to such information is any person engaged in commercially servicing or repairing, road side rescuing, inspecting or testing of vehicles or in the manufacturing or selling replacement or retro-fit components, diagnostic tools and test equipment.</p>
7.	Modifications of the vehicle model
7.1	Every modification in the essential characteristics of the vehicle model shall be intimated by the vehicle manufacturer to the test agency which type approved the vehicle model. The test agency may either,
7.2	Consider that the vehicle with the modifications made may still comply with the requirement, or require a further test to ensure further compliance.
7.3	In case of 7.2 above, the testing agency shall extend the type approval covering the modified specification or the vehicle model shall be subjected to necessary tests as per the guidelines for extension of approval (clause 8). In case, the vehicle complies with the requirements, the test agency shall extend the type approval.
8.	Guidelines for Extension of Approval of the vehicle for OBD.
8.1	<p>Approval granted to a vehicle type with respect to the OBD system may be extended to different vehicle types belonging to the same vehicle-OBD family as described in Annex III. The engine emission control system must be identical to that of the vehicle already approved and comply with the description of the OBD engine family given in Annex III, regardless of the following vehicle characteristics:</p> <ul style="list-style-type: none"> <li>- engine accessories,</li> <li>- tyres,</li> <li>- equivalent inertia,</li> <li>- cooling system,</li> <li>- overall gear ratio,</li> <li>- transmission type,</li> <li>- type of bodywork.</li> </ul>
8.2	In a vehicle model, which is previously approved for OBD parameter, if there is any change in OBD parameter, then the discontinuity testing for the changed OBD parameter only needs to be conducted as mutually agreed between the testagency and vehicle manufacturer if manufacturer can prove that changed OBD parameter don't have any interaction with other OBD parameters

**Figure 1: OBD-1 TEST  
PROCEDURE FLOW CHART**

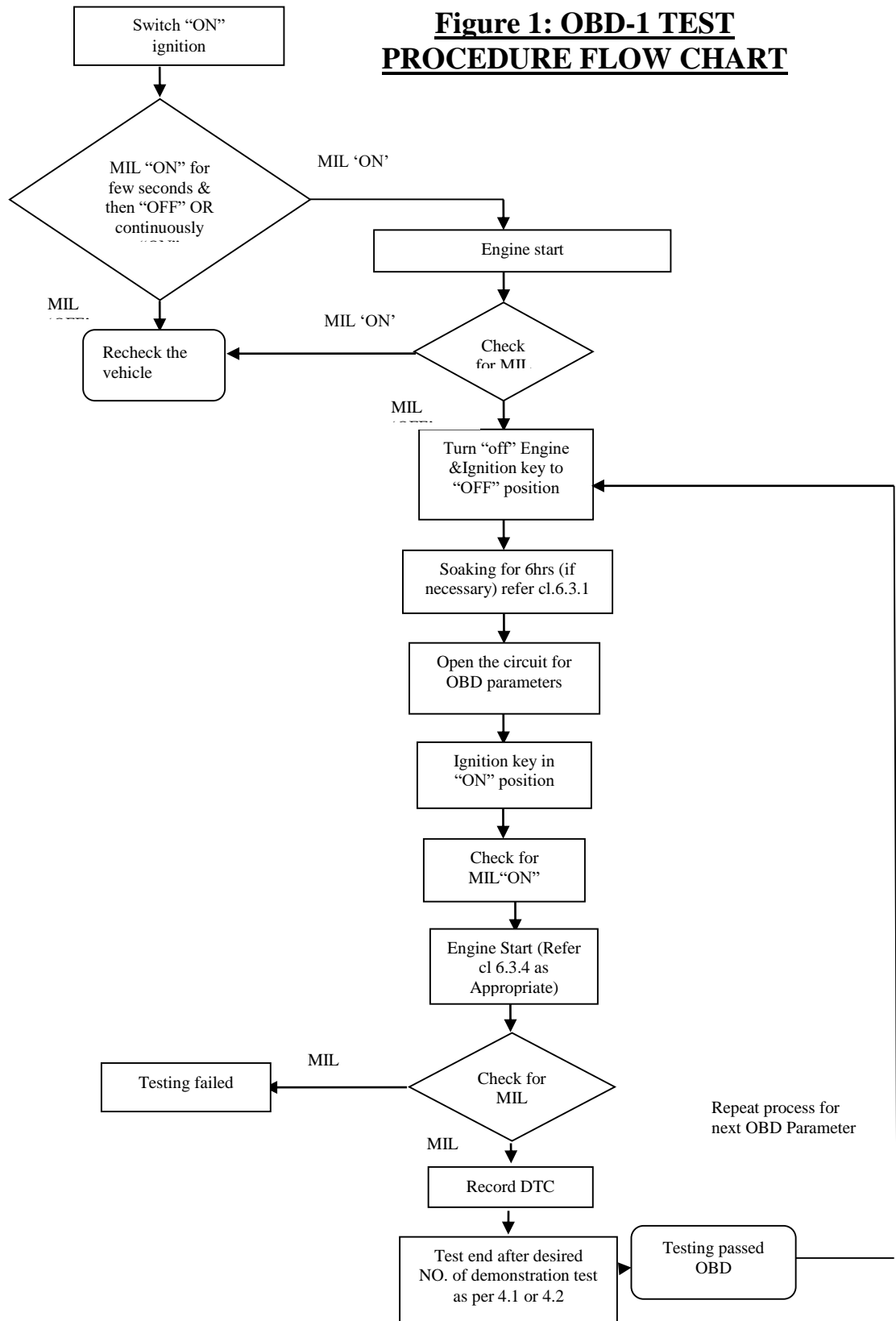

**Annexure 1**

**OBD specification table format**

Component/ System	Fault Code	Monitor Strategy Description	Malfunction Criteria	Secondary Parameter s	MIL Illuminations



**Appendix 2**

**OBD Flow Chart Application Table Format**

FUNCTION	DEMO	DTC	TYPE	CONFIGURATION

DEMO: The monitoring sysytem simulated for the pupose of the type-approval is marked with the tested vehicle and date.

### Annexure 3

#### ESSENTIAL CHARACTERISTICS OF THE VEHICLE FAMILY

1	<b>PARAMETERS DEFINING THE OBD FAMILY</b>
	The OBD family may be defined by basic design parameters, which must be common to vehicles within the family. In some cases there may be interaction of parameters. These effects must also be taken into consideration to ensure that only vehicles with similar exhaust emission characteristics are included within an OBD family.
2.	<p>To this end, those vehicle types whose parameters described below are identical are considered to belong to the same engine-emission control/OBD system combination</p> <p>Engine:</p> <ul style="list-style-type: none"><li>- combustion process (i.e. SI, CI, twostroke,four-stroke),</li><li>- method of engine fuelling (i.e. carburetor or fuel injection).</li><li>- fuel type (i.e petrol, diesel, NG, LPG, bi-fuel petrol/NG, bi-fuel petrol/LPG)</li></ul> <p>Emission control system:</p> <ul style="list-style-type: none"><li>- type of catalytic converter (i.e. oxidation, three-way, heated catalyst, other),</li><li>- type of particulate trap,</li><li>- secondary air injection (i.e. with or without),</li><li>- exhaust gas recirculation (i.e. with or without)</li></ul> <p>OBD parts and functioning:</p> <ul style="list-style-type: none"><li>- the methods of OBD functional monitoring, malfunction detection and malfunction indication to the vehicle driver.</li></ul>

<b>PART VI</b>	<b>Document on Test Methods, Testing Equipment and Related Procedures for Testing Type Approval and Conformity of Production (COP) of Vehicles for Emission as per CMV Rules 115,116 and 126.</b>				
<b>1</b>	<b>Corrected clause as follows:</b>				
	<b>Part VI</b>				
	Substitute the following clause 11(b) for the existing cause under title <b>“COP PERIOD AND SELECTION OF RANDOM SAMPLE</b> For 2 , 3 wheelers and Quadricycle (Bharat Stage II , Bharat Stage III and Bharat Stage IV ) COP frequency and samples:				
	Sl. No.	Type of vehicle	Annual production / Import		COP frequency
			Exceeding	upto	
	(1)	(2)	(3)	(4)	(5)
	1.	Two-wheeler , Three wheeler and Quadricycle	250 per 6 months	10000 per year	Once every year
	2.	Two-wheeler	10000 per year	150000 per 6 months	Once every 6 months
	3.	Two-wheeler	150000 per 6 months	---	Once every 3 months
	4.	Three wheeler and Quadricycle	10000 per year	75000 per 6 months	Once every 6 months
	5.	Three wheeler and Quadricycle	75000 per 6 months	---	Once every 3 months



